

Table of Contents

Section	Subject	Page	
Contact	Contacting Accumulators, Inc.	2	
Ordering	Standard Part Number List	3	
	Accumulator Ordering Table	4	
	Special Order Products	5	
Product Drawings	AccuMight Diaphragm Accumulators	6	
	3000 PSI Accumulators	10	
	5000 & 6000 PSI Accumulators	14	
	10000 PSI Accumulators	18	
	Hi-Flow Accumulators	19	
	Gas Bottles	21	
	Float Accumulators	24	
	Transfer Barrier Accumulators	25	
	Piston Accumulators	28	
	Fluid Port Specifications	29	
	Gas Valve Specifications	30	
	Accessories	Charging and Gauging Assemblies & Components	31
Accumulator Accessory Kits		33	
Permanent Mount Pressure Monitor		35	
Mounting Hardware		36	
Tools		40	
Accumulator Safety Blocks		41	
Custom Machined Parts for all industries		42	
Machined Parts	Shell Interior Cleaning Procedures	43	
	Corrosion Protection Specifications	43	
	FAQ's	44	
	Bladder Material Specifications	46	
	Bladder Elastomer Compatibility	46	
Product Specifications	Bladder Special Orders	46	
	Accumulator Selection, Commissioning, Installation & Maintenance	47	
	Bladder Care Instructions	51	
	Bladder Replacement - Removal	51	
	Bladder Replacement - Installation & Precharging	52	
	Precharge Maintenance	53	
	Charging & Gauging Recommended Accessories	53	
	Bladder Storage	54	
	Bladder failure: Most common causes & Bladder FAQs	54	
	Sizing	Sizing for Fluid Storage, Line Shock	57
		Sizing for Suction Stabilization & Pulsation Dampeners	58
		Sizing Polytropic Coefficient Table	58
	General	Company History	59
HAZMAT Shipments & DOT Exemption		60	
Alternate Design Codes and Inspection Agencies		61	
Returned Goods Authorization (RGA) Procedure		62	
Terms & Conditions of Sale		63	
Product Limited Warranty		64	
AccuMight Operating Instructions & Specifications		66	
Repair & Service Center	Repair of Accumulators (Most Brands) and AccuMights	70	
Index	Alphabetical Index	71	

The information contained in this catalog is for the exclusive use of our customers. Assigned stocking distributors may reproduce all or any portion of this catalog for internal use or for the promotion of our products. Permission for other customers must be requested and granted *in writing* from the Accumulators, Inc. Sales Department. All information in this catalog is copyrighted 1987 through 2009 by Accumulators, Inc. Accumulators, Inc. name and logo, AccuMight name and logo, Acc Inc, and ACCINC are all registered Trademarks and Service Marks of Accumulators, Inc. accumulators.com is a registered site on the World Wide Web. Accumulators, Inc. is not responsible for typographical errors.



Contact Information

How to contact us

Main Phone Number: 713-465-0202

Main Fax Number: 713-468-1618

Web Site URL: www.accumulators.com

Main email Address: info@accumulators.com

Mailing Address:

1175 Brittmoore Road
Houston, Texas 77043-5003

Shipping Address:

1175 Brittmoore Road
Houston, Texas 77043-5003

Remittance Address:

PO Box 497168
Garland, Texas 75049-7168

You may download this catalog from our website at www.accumulators.com
We can also email this catalog to you. Contact us at info@accumulators.com

Visiting Accumulators, Inc.

We are located 18 miles west of Downtown Houston in what is called the Town & Country Area. We are just north of the I-10 Katy Freeway, just west of the SH-8 Sam Houston Toll Road. Detailed directions and a map to our location is available on our website at www.accumulators.com



Standard Part Number List

(Basic part numbers without optional configurations)

Accumulators: Bottom Repairable

New!

Size/Pressure	3000 psi	4000 psi	5000 psi	6000 psi	10,000 psi
1 quart	A1QT3100	***	A1QT5100	***	***
1 gal	A13100	A14100	***	A15100	***
2.5 gal	A2.53100	A2.54100	***	A2.56100	A2.510100
5 gal	A53100	A54100	***	A56100	A510100
10 gal	A103100	A104100	***	A106100	A1010100
11 gal	A113100	***	***	***	***
15 gal	A153100	A154100	***	A156100	A1510100

Accumulators: Top or Bottom Repairable

New!

Size/Pressure	3000 psi	4000 psi	5000 psi	6000 psi	10,000 psi
2.5 gal	A2.5TR3100	A2.5TR400	***	A2.5TR6100	A2.5TR10100
5 gal	A5TR3100	A5TR4100	***	A5TR6100	A5TR10100
10 gal	A10TR3100	A10TR4100	***	A10TR6100	A10TR10100
11 gal	A11TR3100	***	***	***	***
15 gal	A15TR3100	A15TR4100	***	A15TR6100	A15TR10100

Bladder Kits

New!

Size/Pressure	3000 psi	5000 psi	6000 psi	10,000 psi
1 quart	AI-1QT-3KT	AI-1QT-5-3KT	***	***
1 gal	AI-1-3KT	AI-1-5-3KT	AI-1-5-3KT	***
2.5 gal	AI-2.5-3KT	AI-2.5-6-3KT	AI-2.5-6-3KT	AI-2.5-10-3KT
5 gal	AI-5-3KT	AI-5-6-3KT	AI-5-6-3KT	AI-5-10-3KT
10 gal	AI-10-3KT	AI-10-6-3KT	AI-10-6-3KT	AI-10-10-3KT
11 gal	AI-11-3KT	***	***	***
15 gal	AI-15-3KT	AI-15-6-3KT	AI-15-6-3KT	AI-15-10-3KT

Oil Port Assemblies 3000/5000/6000 psi

New!

Thread/Type	1 quart	1 gal	2.5-15 gal	10,000 psi
NPT	AI-1QT-400	AI-1-400	AI-S-400	Call Factory for Option
	AI-1QT-5-400	AI-1-5-400	AI-S-6-400	
SAE (-3)	AI-1QT-400-3	AI-1-400-3	AI-S-400-3	
	AI-1QT-5-400-3	AI-1-5-400-3	AI-S-6-400-3	
Split Flange (-4)	AI-1QT-400-4	AI-1-400-4	AI-S-400-4	
	AI-1QT-5-400-4	AI-1-5-400-4	AI-S-6-400-4	



See the Assembly Drawings and Price List for a more complete listing of options for materials, elastomers, thread types, coatings, configurations and other options.

Some units may have extended delivery times

Accumulator Ordering Table

(For Catalog Items)

Use the table below to determine the part number for your desired accumulator. For help selecting your bladder elastomer, visit our website at www.accumulators.com/technical-information.html. You can also use our website to request a quote on accumulators and all our other products at www.accumulators.com/products_online_esp.html, or contact us by phone at 713-465-0202 or by email at info@accumulators.com.

Select the desired option from each list and place the corresponding code in its proper place

Approval Code	Size	Model	Pressure	Oil Port	Bladder	Service
---------------	------	-------	----------	----------	---------	---------

Example: A 15 _____ 3100 1 _____ SS = **A1531001SS**

Option	Code
APPROVAL CODE	
ASME only ¹	A
DNV	N
ABS	B
CE	P
CRN	R
ABS & DNV	D
SIZE	
1 Quart	1QT
1 Gallon	1
2.5 Gallon	2.5
5 Gallon	5
10 Gallon	10
11 Gallon	11
15 Gallon	15
40 Gallon ²	40

Option	Code
MODEL	
Bottom Repairable ¹	BLANK
Top Repairable	TR
Float	F
High Flow	H
High Flow, Top Repairable	HT
Gas Bottle	GX ³
Transfer Barrier	TBX ³
PRESSURE	
3000 PSI	3100
4000 PSI	4100
5000 PSI	5100
6000 PSI	6100
10000 PSI	10100

Option	Code
1 QUART OIL PORTS	
3/4" NPT ¹	BLANK
1 1/16"-12 SAE	3
Code 61, 3/4" SAE Split Flange	4
1 GAL. OIL PORTS	
1 1/4" NPT ¹	BLANK
1 5/8"-12 SAE	3
Code 61, 1 1/2" SAE Split Flange	4
2.5-15 GAL OIL PORTS	
2" NPT ¹	BLANK
1 1/4" NPT	1
50mm	2
1 7/8"-12 SAE	3
Code 61, 2" SAE Split Flange	4
Code 62, 1.5" SAE Split Flange	15
Code 62, 1.5" SAE Split Flange; Seal Sub, Male	98

Option	Code
BLADDER	
Buna-Nitrile ¹	BLANK
Butyl	B
EPR	E
Fluorocarbon	V
Low-Temp	L
Extreme Low-Temp	X
SERVICE³	
Oil Service ¹	BLANK
Water Service	WS
Chemical Service	PS
Special Service	SS
Extreme Service	XS
Economy Service	CS

1. Standard
2. 40 Gallon size only available in Float model; please contact Sales Dept.
3. Several options available; see our website or contact us for assistance

Only the most popular options are shown above.
We have many more options and products available.
Contact us at 713-465-0202 or at info@accumulators.com

Special Order Accumulator Products

Accumulators, Inc. offers many special products and services including Buoyant Float Accumulators, interior and exterior coatings, alternate design approvals and user-specified custom items.

Buoyant Float Accumulators

Our patented non-separator type Float Accumulators are an effective solution for high and low temperature emergency applications that none of our competitors can accommodate. By eliminating the bladder, units may be operated in frigid or sweltering environments. Float Accumulators are particularly well-suited for subsea and off-shore applications. All Float Accumulators also have extensive corrosion resistance to ensure there are no mechanical failures for years into the future. Available in 10 gallon through 40 gallon sizes, 3000-6000 psi. [See more details about Float Accumulators.](#)

High Flow Accumulators

We offer a full line of [High Flow Accumulators](#) for applications that require an instantaneous flow rate of over 200 gallons per minute. Our standard High Flow Accumulators can handle up to 600 gpm for oil, water or special fluids.

Special Services

We offer a variety of special services on all of our accumulators. We offer four main service types (below), but can customize to meet your needs. To order, add the 2-letter code in parenthesis to our standard part number.

(WS) Water Service Accumulators

For high water content applications and when internal corrosion protection is necessary, these units have Phenolic coated interiors and two-coat enamel-painted exteriors. Contains a mix of electroless-nickel plated and stainless steel components.

(PS) Water & Chemical Service Accumulators

Our PS units have phenolic-coated interiors for corrosion protection and primed exteriors with stainless steel components. Used primarily for high water content applications when stainless steel parts are necessary.

(SS) Special Service Accumulators

Both the interior and exterior of these units are electroless-nickel plated, perfect for chemical and harsh environment applications. Stainless steel components.

(XS) Extreme Service Accumulators

Extreme Service Accumulators were created specifically for sub-sea drilling. These units have been designed with maximum corrosion protection, high-pressure fittings, low-temperature components and improved external sealing. Each unit incorporates many of the best features of several Special Service units currently being operated at extreme depths, plus additional innovations.

	WS	PS	SS	XS
Phenolic Interior	✓	✓		✓
Stainless Parts		✓	✓	✓
Nickel Plated Shell			✓	
Primed Exterior Only		✓		
Nickel Plated Parts	✓			
Marine Epoxy Exterior	✓			✓
High Pressure Fittings				✓
Low Temp Components				✓

Alternate Design Approvals

Our accumulators are designed to the strict guidelines of the ASME Boiler and Pressure Vessel Code and are so stamped with the "U" symbol and registered with the National Board of Boiler and Pressure Vessel Inspectors. Many domestic and foreign code approvals or authority reviews, such as CE, DNV, ABS, CRN, Lloyds, and others are available by request at additional cost. Acc Inc can also modify existing units under the ASME "R" stamp. Our extensive Quality department can handle even the most stringent requirements.

Custom Engineered Products

Accumulators, Inc. can design products to fit your precise requirements. We can help you select special fluid or gas ports, special elastomers, and special coatings. These products can be assigned proprietary part numbers for your exclusive use. Perfect for OEM applications.

6 and 20 cubic inch 3000 psi AccuMight[®]

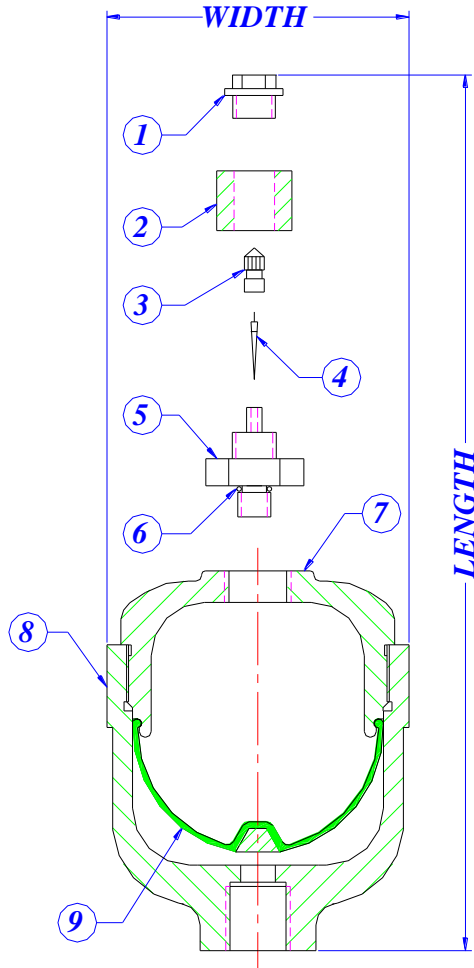

List of Component Parts		Alternate Service ¹		
Description	Part Number (OS)	WS	SS	XS
1 Safety Cap	AI-1QT-308		N/A ²	N/A ²
1 Safety Cap O-Ring	AI-1QT-309		N/A ²	N/A ²
2 Protective Cap	AI-1QT-306		-4-SS	-4-SS
3 Valve Cap	AI-1QT-303			
4 Valve Core	AI-S-304			
5 AccuMight [®] Gas Valve	AM-309			
6 Gas Valve O-Ring	AM-310			
7 Shell	Not for Sale	N/A	N/A	N/A
8 Label	AM-413			
9 Bladder ³				
	Buna-Nitrile	AM-X-3KT		
	Fluorocarbon	AM-X-3KT-V		
	Low Temp Buna			

Standard Configuration

ASTM A 350 LF2 Forged Steel Shell
 Shell Externally Painted Black
³/₄"-16 SAE Female Fluid Port
 Buna-Nitrile Rubber Components

Optional Configuration (at extra cost)

Resin Coatings, Internal (WS)
 Electroless Nickel Plating, Internal & External (SS)
 Resin Coating – ID, 3 Part Marine Epoxy Paint – OD (XS)
 Stainless Steel Components
 Fluorocarbon Bladder
 Call Factory for Other Options

Dimensions ⁴			
Part Number	Length	Width	Weight
AM631003	5.8"	3.0"	4.4 lbs
AM2031003	6.8"	3.9"	6.6 lbs

1 OS-Oil Service, WS- Water Service, SS-Special Service, XS-Extreme Service
 2 Special service accumulator uses a solid protective cap
 3 Insert the size of the AccuMight[®] for X, i.e. AM-6-3KT for a 6 cu. in. bladder
 4 Nominal dimensions. Manufacturing variations will occur

30 and 45 cubic inch 3000 psi AccuMight[®]

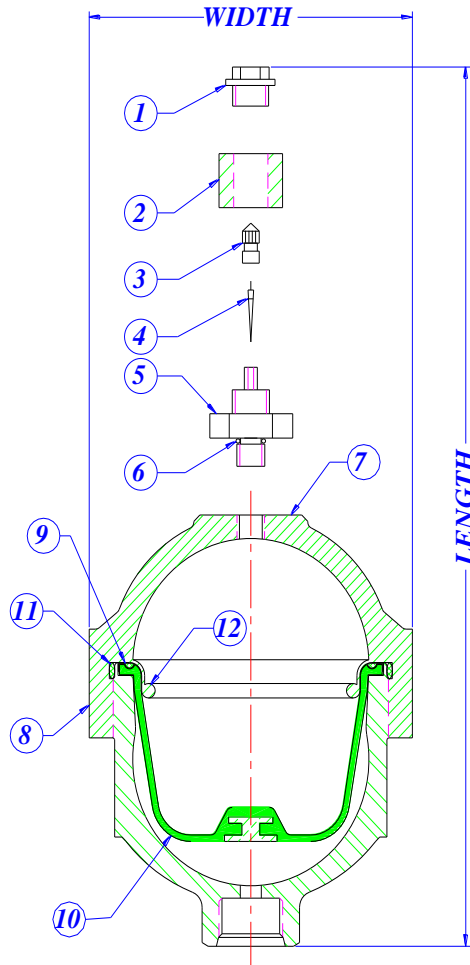

List of Component Parts		Alternate Service ¹			
		Part Number (OS)	WS	SS	XS
1	Safety Cap	AI-1QT-308		N/A ²	N/A ²
1	Safety Cap O-ring	AI-1QT-309		N/A ²	N/A ²
2	Protective Cap	AI-1QT-306	-SS	-4-SS	-4-SS
3	Valve Cap	AI-1QT-303			
4	Valve Core	AI-S-304			
5	AccuMight [®] Gas Valve	AM-309			
6	Gas Valve O-Ring	AM-310			
7	Shell	Not for Sale	NA/	N/A	N/A
8	Label	AM-413			
9	Teflon Ring	AM-411			
10	Bladder Kit ³				
	Buna-Nitrile	AM-45-3KT			
	Fluorocarbon	AM-45-3KT-V			
11	Metal Ring	AM-412			
12	O-Ring	AM-410-L			

Standard Configuration

ASTM A 350 LF2 Forged Steel Shell
 Shell Externally Painted Black
 1 1/16"-12 SAE Female Fluid Port
 Buna-Nitrile Rubber Components

Optional Configuration (at extra cost)

Resin Coatings, Internal (WS)
 Electroless Nickel Plating, Internal & External (SS)
 Resin Coating – ID, 3 Part Marine Epoxy Paint – OD (XS)
 Stainless Steel Components
 Call Factory for Other Options

Dimensions ⁴			
Part Number	Length	Width	Weight
AM3031003	7.5"	4.5"	9.4 lbs
AM4531003	8.2"	5.4"	13.3 lbs

¹ OS-Oil Service, WS- Water Service, SS-Special Service, XS-Extreme Service

² Special service accumulator uses a solid protective cap

³ Bladder kit consists of the following parts: 9, 10, and 12

⁴ Nominal dimensions. Manufacturing variations will occur

45 and 60 cubic inch Top Repairable 3000 psi AccuMight[®]

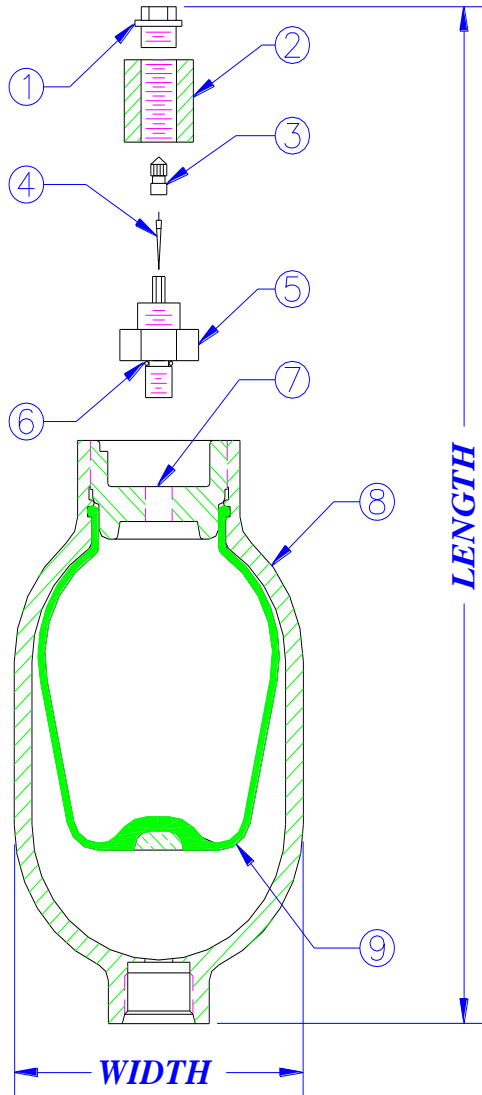

List of Component Parts		Alternate Service ¹			
		Part Number (OS)	WS	SS	XS
1	Safety Cap	AI-1QT-308		N/A ²	N/A ²
1	Safety Cap O-Ring	AI-1QT-309		N/A ²	N/A ²
2	Protective Cap	AI-1QT-306	-SS	-4-SS	-4-SS
3	Valve Cap	AI-1QT-303			
4	Valve Core	AI-S-304			
5	AccuMight [®] Gas Valve	AM-309			
6	Gas Valve O-Ring	AM-310			
7	Shell	Not for Sale	N/A	N/A	N/A
8	Label	AM-413			
9	Bladder Kit ³				
	Buna-Nitrile	AM-X-3KT			
	Fluorocarbon	AM-X-3KT-V			

Standard Configuration

ASTM A 250 LF2 Forged Steel Shell
 Shell Externally Painted Black
 1 1/16"-12 SAE Female Fluid Port
 Buna-Nitrile Rubber Components

Optional Configuration (at extra cost)

Resin Coatings, Internal (WS)
 Electroless Nickel Plating, Internal & External (SS)
 Resin Coating – ID, 3 Part Marine Epoxy Paint – OD (XS)
 Stainless Steel Components
 Call Factory for Other Options

Dimensions ⁴			
Part Number	Length	Width	Weight
AM45TR31003	8.3"	4.6"	9.4 lbs
AM60TR31003	9.0"	4.6"	10.0 lbs

¹ OS-Oil Service, WS- Water Service, SS-Special Service, XS-Extreme Service
² Special service accumulator uses a solid protective cap
³ Insert the size of the AccuMight[®] for X, i.e. AI-90-TR-3KT for a 90 cu. in. TR bladder kit. Bladder kit consists of the following part: 9
⁴ Nominal dimensions. Manufacturing variations will occur

**90 and 150 cubic inch 3000 psi
AccuMight[®]**

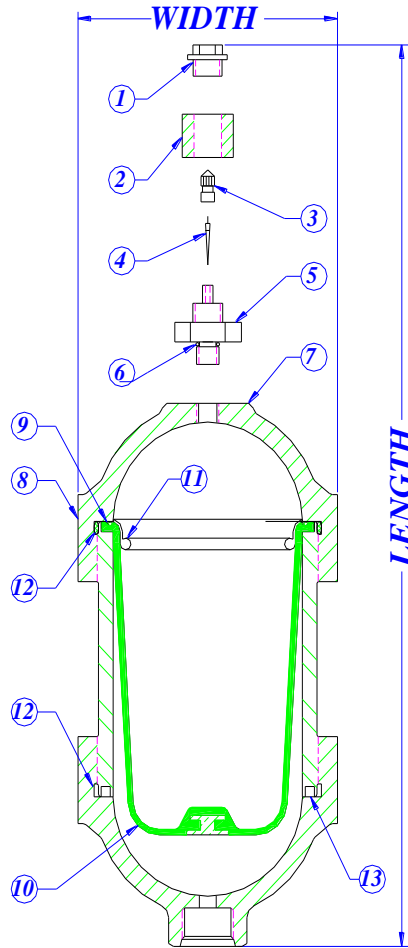

List of Component Parts		Alternate Service ¹		
Description	Part Number (OS)	WS	SS	XS
1 Safety Cap	AI-1QT-308		N/A ²	N/A ²
1 Safety Cap O-Ring	AI-1QT-309		N/A ²	N/A ²
2 Protective Cap	AI-1QT-306	-SS	-4-SS	-4-SS
3 Valve Cap	AI-1QT-303			
4 Valve Core	AI-S-304			
5 AccuMight [®] Gas Valve	AM-309			
6 Gas Valve O-Ring	AM-310			
7 Shell	Not for Sale	N/A	N/A	N/A
8 Label	AM-413			
9 Teflon Ring	AM-411			
10 Bladder Kit ³				
Buna-Nitrile	AM-X-3KT			
Fluorocarbon	AM-X-3KT-V			
11 Metal Ring	AM-412			
12 Large O-Ring	AM-410-L			
13 Small O-Ring	AM-410-S			

Standard Configuration

ASTM A 250 LF2 Forged Steel Shell
Shell Externally Painted Black
1 1/16"-12 SAE Female Fluid Port
Buna-Nitrile Rubber Components

Optional Configuration (at extra cost)

Resin Coatings, Internal (WS)
Electroless Nickel Plating, Internal & External (SS)
Resin Coating – ID, 3 Part Marine Epoxy Paint – OD (XS)
Stainless Steel Components
Call Factory for Other Options

Dimensions ⁴			
Part Number	Length	Width	Weight
AM9031003	12.1"	5.4"	22.1 lbs
AM15031003	18.1"	5.4"	31.9 lbs

¹ OS-Oil Service, WS- Water Service, SS-Special Service, XS-Extreme Service

² Special service accumulator uses a solid protective cap

³ Insert the size of the AccuMight[®] for X, i.e. AI-90-3KT for a 90 cu. in. bladder kit. Bladder kit consists of the following parts: 9, 10, 12, and 13

⁴ Nominal dimensions. Manufacturing variations will occur

1 Quart 3000 psi Bottom Repairable Accumulators

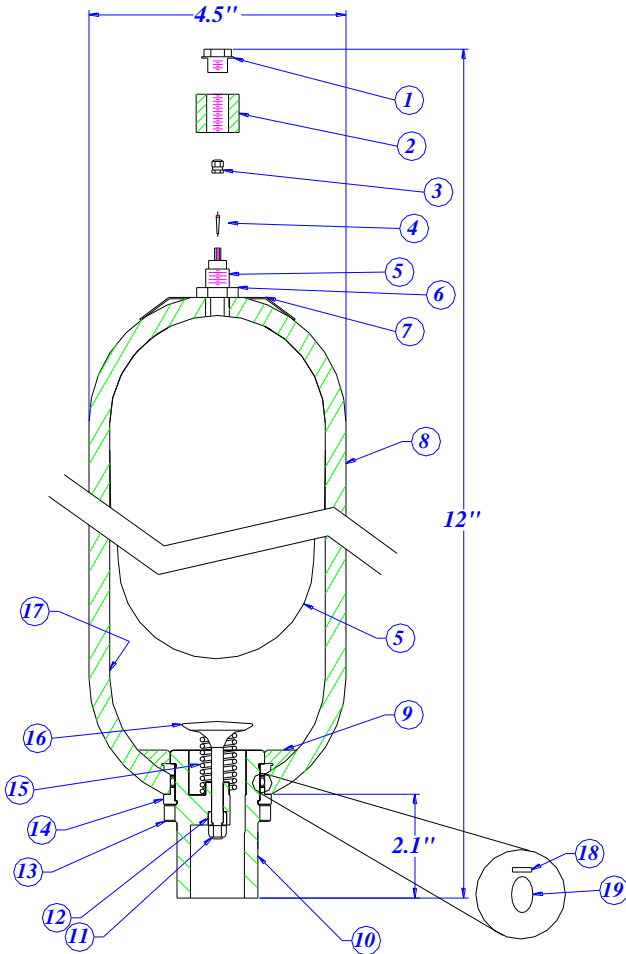

List of Component Parts		Alternate Service ¹			
		Part Number (OS)	WS	SS	XS
1	Safety Cap	AI-1QT-308		N/A ²	N/A ²
1	Safety Cap O-Ring	AI-1QT-309		N/A ²	N/A ²
2	Protective Cap	AI-1QT-306	-SS	-4-SS	-4-SS
3	Valve Cap	AI-1QT-303			
4	Valve Core	AI-S-304			
5	Bladder Kit ³				
	Buna-Nitrile	AI-1QT-3KT		-SS	-SS
	Butyl	AI-1QT-3KT-B		-SS	-SS
	EPR	AI-1QT-3KT-E		-SS	-SS
	Fluorocarbon	AI-1QT-3KT-V		-SS	-SS
	Hydrin	AI-1QT-3KT-H		-SS	-SS
	Low Temp Buna	AI-1QT-3KT-L		-SS	-SS
6	Hex Jam Nut	AI-1QT-305	-SS	-SS	-SS
7	Name Plate	AI-1QT-413			
8	Caution Label	AI-1QT-414			
8	Information Label	AI-1QT-421			
9	Anti-Extrusion Ring				
	Buna-Nitrile	AI-1QT-407	-WS	-WS	-WS
	EPDM	AI-1QT-407-E	-WS	-WS	-WS
	Fluorocarbon	AI-1QT-407-V	-WS	-WS	-WS
10	Fluid Port ⁴	AI-1QT-402	-WS	-SS	-SS
11	Stop Nut	AI-1QT-408	-SS	-SS	-SS
12	Piston	AI-1QT-405	-SS	-SS	-SS
13	Locknut	AI-1QT-403	-WS	-SS	-SS
14	Spacer	AI-1QT-406	-WS	-SS	-SS
15	Spring	AI-1QT-409-SS			
16	Poppet	AI-1QT-404	-SS	-SS	-SS
17	Shell (3000 psi)	Not for Sale	N/A	N/A	N/A
18	Metal Back-Up Ring	AI-1QT-412	-SS	-SS	-SS
19	O-Ring				
	Buna-Nitrile	AI-1QT-410			
	Butyl	AI-1QT-410-B			
	EPR	AI-1QT-410-E			
	Fluorocarbon	AI-1QT-410-V			

Standard Configuration

SA 372 Chrome-moly Steel Shell
 C-1018 and 4130 or 4140 Components
³/₄" NPT Female Fluid Port
 Buna-Nitrile Rubber Components

Optional Configuration (at extra cost)

AN Gas Valve
 Resin Coatings, Internal (WS)
 Electroless Nickel Plating, Internal & External (SS)
 Resin Coating – ID, 3 Part Marine Epoxy Paint – OD (XS)
 Stainless Steel Components
 Foreign and Domestic Codes
 Call Factory for Other Options

Dimensions⁵

Part Number	Weight
AIQT3100	9.5 lbs

Fluid Port Options

Fluid Port Type	Designation
³ / ₄ " NPT Female	None
Metric Female	-2
1 ¹ / ₁₆ "-12 SAE Female	-3
Code 61, ³ / ₄ " SAE Split Flange	.4
BSPP Female	-7
Other	Call
Special Materials	Call

¹ OS-Oil Service, WS- Water Service, SS-Special Service, XS-Extreme Service
² Special service accumulator uses a solid protective cap
³ Bladder kit consists of the following parts: 3, 4, 5, 18, and 19
⁴ See Oil Port Configuration for options
⁵ Nominal dimensions. Manufacturing variations will occur. Allow ⁺/₂".

1 Gallon 3000 psi Bottom Repairable Accumulators

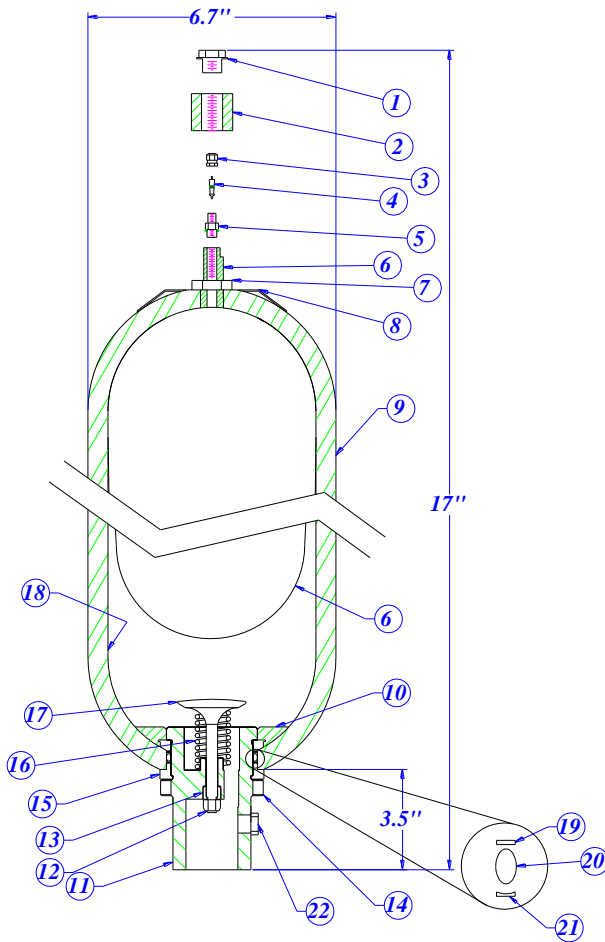

List of Component Parts		Alternate Service ¹			
		Part Number (OS)	WS	SS	XS
1	Safety Cap	AI-S-308		N/A ²	N/A ²
1	Safety Cap O-Ring	AI-S-309		N/A ²	N/A ²
2	Protective Cap	AI-306	-SS	-4-SS	-4-SS
3	Valve Cap	AI-S-303			
4	Valve Core	AI-S-304			
5	GT Gas Valve	AI-GT3-309			
5	Gas Valve O-Ring	AI-GT3-311			
6	Bladder Kit ³				
	Buna-Nitrile	AI-1-3KT		-SS	-SS
	Butyl	AI-1-3KT-B		-SS	-SS
	EPR	AI-1-3KT-E		-SS	-SS
	Fluorocarbon	AI-1-3KT-V		-SS	-SS
	Hydrin	AI-1-3KT-H		-SS	-SS
	Low Temp Buna	AI-1-3KT-L		-SS	-SS
7	Hex Jam Nut	AI-S-305	-SS	-SS	-SS
8	Name Plate	AI-S-413			
9	Caution Label	AI-S-421			
10	Anti-Extrusion Ring				
	Buna-Nitrile	AI-1-407	-WS	-WS	-WS
	EPDM	AI-1-407-E	-WS	-WS	-WS
	Fluorocarbon	AI-1-407-V	-WS	-WS	-WS
11	Fluid Port ⁴	AI-1-402	-WS	-SS	-SS
12	Stop Nut	AI-1-408	-SS	-SS	-SS
13	Piston	AI-1-405	-SS	-SS	-SS
14	Locknut	AI-1-403	-WS	-SS	-SS
15	Spacer	AI-1-406	-WS	-SS	-SS
16	Spring	AI-1-409-SS			
17	Poppet	AI-1-404	-SS	-SS	-SS
18	Shell	Not for Sale	N/A	N/A	N/A
19	Metal Back-Up Ring	AI-1-412	-SS	-SS	-SS
20	O-Ring				
	Buna-Nitrile	AI-1-410			
	EPDM	AI-1-410-E			
	Fluorocarbon	AI-1-410-V			
21	Rubber Back-Up Ring	AI-1-411			
22	Bleed Plug				
	¹ / ₄ " NPT	AI-S-418	-SS	-SS	-SS
	⁷ / ₁₆ "-20 SAE	AI-S-419	-SS	-SS	-SS

Standard Configuration

SA 372 Chrome-moly Steel Shell
 C-1018 and 4130 or 4140 Components
 1 ¹/₄" NPT Female Fluid Port
 Buna-Nitrile Rubber Components

Optional Configuration (at extra cost)

AN Gas Valve
 Resin Coatings, Internal (WS)
 Electroless Nickel Plating, Internal & External (SS)
 Resin Coating – ID, 3 Part Marine Epoxy Paint – OD (XS)
 Stainless Steel Components
 Foreign and Domestic Codes
 Call Factory for Other Options

Dimensions⁵

Part Number	Weight
A13100	32 lbs

Fluid Port Options

Fluid Port Type	Designation
1 ¹ / ₄ " NPT Female	None
Metric Female	-2
1 ⁵ / ₈ "-12 SAE Female	-3
Code 61, 1 ¹ / ₂ " SAE Split Flange	-4
BSPP Female	-7
Other	Call
Special Materials	Call

¹ OS-Oil Service, WS- Water Service, SS-Special Service, XS-Extreme Service

² Special service accumulator uses a solid protective cap

³ Bladder kit consists of the following parts: 3, 4, 5, 6, 19, 20, and 21

⁴ See Oil Port Configuration for options

⁵ Nominal dimensions. Manufacturing variations will occur. Allow ⁺/₂".

2.5-15 Gallon 3000 psi Bottom Repairable Accumulators

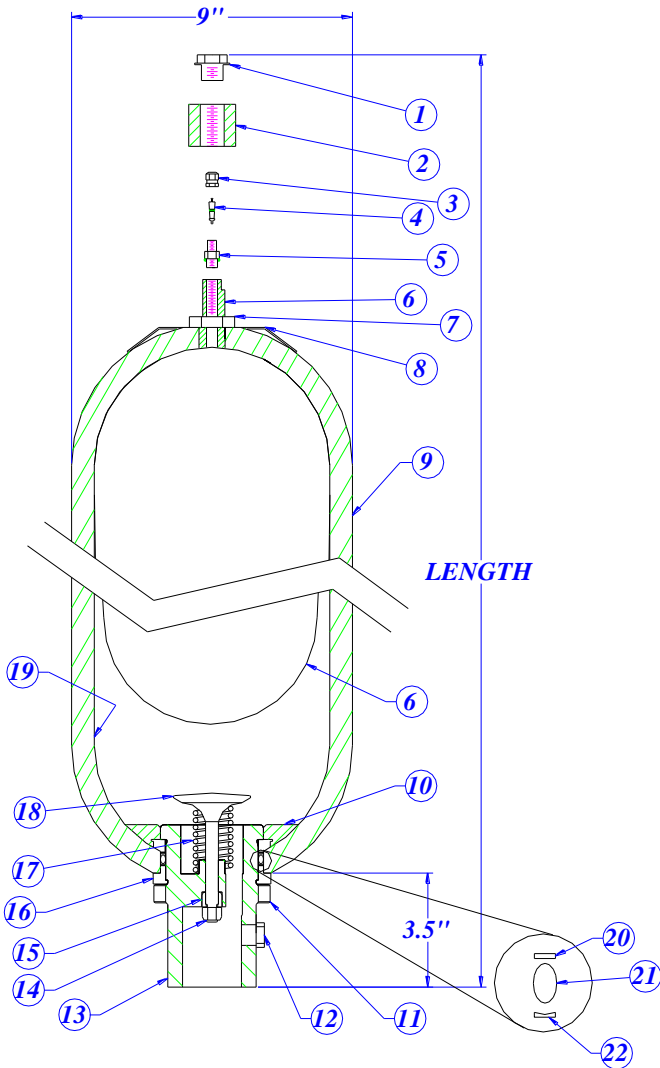

List of Component Parts		Alternate Service ¹		
		WS	SS	XS
Description	Part Number (OS)			
1	Safety Cap	AI-S-308		N/A ²
1	Safety Cap O-Ring	AI-S-309		N/A ²
2	Protective Cap	AI-306	-SS	-4-SS
3	Valve Cap	AI-S-303		
4	Valve Core	AI-S-304		
5	GT Gas Valve	AI-GT3-309		
5	Gas Valve O-Ring	AI-GT3-311		
6	Bladder Kit ³			
	Buna-Nitrile	AI-X-3KT		-SS
	Butyl	AI-X-3KT-B		-SS
	EPR	AI-X-3KT-E		-SS
	Fluorocarbon	AI-X-3KT-V		-SS
	Hydrin	AI-X-3KT-H		-SS
	Low Temp Buna	AI-X-3KT-L		-SS
7	Hex Jam Nut	AI-S-305	-SS	-SS
8	Name Plate	AI-S-413		
9	Caution Label	AI-S-421		
10	Anti-Extrusion Ring			
	Buna-Nitrile	AI-S-407	-WS	-WS
	EPDM	AI-S-407-E	-WS	-WS
	Fluorocarbon	AI-S-407-V	-WS	-WS
11	Locknut	AI-S-403	-WS	-SS
12	Bleed Plug			
	1/4" NPT	AI-S-418	-SS	-SS
	7/16"-20 SAE	AI-S-419	-SS	-SS
13	Fluid Port ⁴	AI-S3-402	-WS	-SS
14	Stop Nut	AI-S-408	-SS	-SS
15	Piston	AI-S-405	-SS	-SS
16	Spacer	AI-S3-406	-WS	-SS
17	Spring	AI-S3-409	-SS	-SS
18	Poppet	AI-S-404	-SS	-SS
19	Shell (3000 psi)	Not for Sale	N/A	N/A
20	Metal Back-Up Ring	AI-S-412	-SS	-SS
21	O-Ring			
	Buna-Nitrile	AI-S-410		
	EPDM	AI-S-410-E		
	Fluorocarbon	AI-S-410-V		
22	Rubber Back-Up Ring	AI-S-411		

Standard Configuration

- SA 372 Chrome-moly Steel Shell
- 2 Piece Replaceable Gas Valve
- C-1018 and 4130 or 4140 Components
- 2" NPT Female Fluid Port
- Buna-Nitrile Rubber Components

Optional Configuration (at extra cost)

- AN Gas Valve
- Resin Coatings, Internal (WS)
- Electroless Nickel Plating, Internal & External (SS)
- Resin Coating – ID, 3 Part Marine Epoxy Paint – OD (XS)
- Stainless Steel Components
- Foreign and Domestic Codes
- Call Factory for Other Options

Dimensions ⁵		
Part Number	Length	Weight
A2.53100	21"	76 lbs
A53100	33"	116 lbs
A103100	54"	212 lbs
A113100	60"	230 lbs
A153100	78"	296 lbs

Fluid Port Options	
Fluid Port Type	Designation
2" NPT Female	None
1 1/4" NPT Female	-1
Metric Female	-2
1 1/8"-12 SAE Female	-3
Code 61, 2" SAE Split Flange	-4
Other	Call
Special Materials	Call

1 OS-Oil Service, WS- Water Service, SS-Special Service, XS-Extreme Service

2 Special service accumulator uses a solid protective cap

3 Insert the size of the accumulator for X, i.e. AI-2.5-3KT for a 2.5-gallon bladder kit. Bladder kit consists of the following parts: 3, 4, 5, 6, 20, 21, and 22

4 See Oil Port Configuration for options

5 Nominal dimensions. Manufacturing variations will occur. Allow +/-2".

2.5-15 Gallon 3000 psi Top Repairable Accumulators

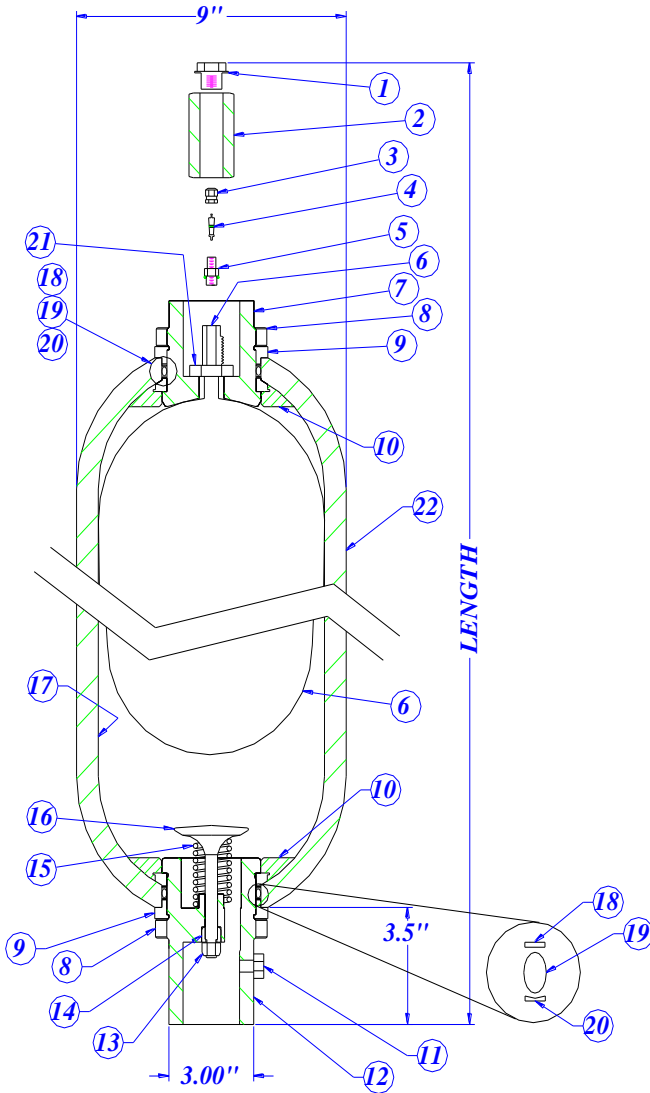

List of Component Parts		Alternate Service ¹		
		WS	SS	XS
Description	Part Number (OS)			
1	Safety Cap	AI-S-308		N/A ²
1	Safety Cap O-Ring	AI-S-309		N/A ²
2	Protective Cap	AI-306	-SS	-4-SS
3	Valve Cap	AI-S-303		
4	Valve Core	AI-S-304		
5	GT Gas Valve	AI-GT3-309		
5	Gas Valve O-Ring	AI-GT3-311		
6	Bladder Kit ³			
	Buna Nitrile	AI-X-3KT		-SS
	Butyl	AI-X-3KT-B		-SS
	EPR	AI-X-3KT-E		-SS
	Fluorocarbon	AI-X-3KT-V		-SS
	Hydrin	AI-X-3KT-H		-SS
	Low Temp Buna	AI-X-3KT-L		-SS
7	Top Load Adapter	AI-TR3-208	-WS	-SS
8	Locknut, Qty 2	AI-S-403	-WS	-SS
9	Spacer, Qty 2	AI-S3-406	-WS	-SS
10	Anti-Extrusion Ring, Qty 2			
	Buna-Nitrile	AI-S-407	-WS	-WS
	EPDM	AI-S-407-E	-WS	-WS
	Fluorocarbon	AI-S-407-V	-WS	-WS
11	Bleed Plug			
	^{1/4} " NPT	AI-S-418	-SS	-SS
	^{7/16} "-20 SAE	AI-S-419	-SS	-SS
12	Fluid Port ⁴	AI-S3-402	-WS	-SS
13	Stop Nut	AI-S-408	-SS	-SS
14	Piston	AI-S-405	-SS	-SS
15	Spring	AI-S-409	-SS	-SS
16	Poppet	AI-S-404	-SS	-SS
17	Shell (3000 psi)	Not for Sale	N/A	N/A
18	Metal Back-Up Ring, QTY 2	AI-S-412	-SS	-SS
19	O-Ring, Qty 2			
	Buna-Nitrile	AI-S-410		
	Butyl	AI-S-410-B		
	EPR	AI-S-410-E		
	Fluorocarbon	AI-S-410-V		
20	Rubber Back-Up Ring, Qty 2	AI-S-411		
21	Hex Jam Nut	AI-S-305	-SS	-SS
22	Caution Label	AI-S-421		

Standard Configuration

- SA 372 Chrome-moly Steel Shell
- 2 Piece Replaceable Gas Valve
- C-1018 and 4130 or 4140 Components
- 2" NPT Female Fluid Port
- Buna-Nitrile Rubber Components

Optional Configuration (at extra cost)

- AN Gas Valve
- Resin Coatings, Internal (WS)
- Electroless Nickel Plating, Internal & External (SS)
- Resin Coating – ID, 3 Part Marine Epoxy Paint – OD (XS)
- Stainless Steel Components
- Foreign and Domestic Codes
- Call Factory for Other Options

Dimensions ⁵		
Part Number	Length	Weight
A2.5TR3100	21"	78 lbs
A5TR3100	33"	118 lbs
A10TR3100	54"	214 lbs
A11TR3100	60"	232 lbs
A15TR3100	78"	298 lbs

Fluid Port Options	
Fluid Port Type	Designation
2" NPT Female	None
1 1/4" NPT Female	-1
Metric Female	-2
1 7/8"-12 SAE Female	-3
Code 61, 2" SAE Split Flange	-4
Other	Call
Special Materials	Call

¹ OS-Oil Service, WS- Water Service, SS-Special Service, XS-Extreme Service

² Special service accumulator uses a solid protective cap

³ Insert the size of the accumulator for X, i.e. AI-2.5-3KT for a 2.5 gallon bladder kit. Bladder kit consists of the following parts: 3, 4, 5, 6, 18, 19, and 20

⁴ See Oil Port Configuration for options

⁵ Nominal dimensions. Manufacturing variations will occur. Allow +/-2".

1 Quart 5000 psi Bottom Repairable Accumulators

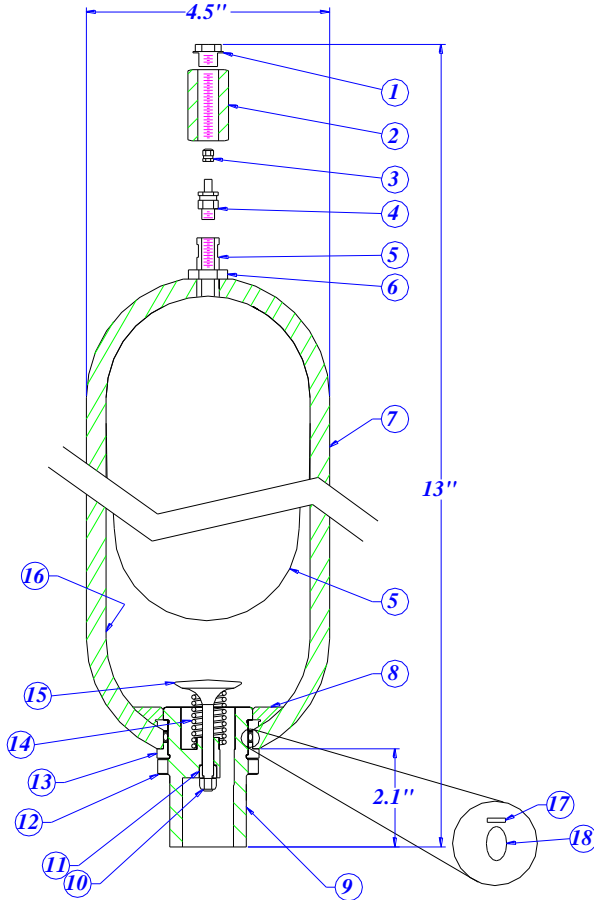

List of Component Parts		Alternate Service ¹			
		Part Number (OS)	WS	SS	XS
1	Safety Cap	AI-S-308		N/A ²	N/A ²
1	Safety Cap O-Ring	AI-S-309		N/A ²	N/A ²
2	Protective Cap	AI-306-1	-SS	-2-SS	-2-SS
3	Valve cap	AI-S-303			
4	Gas Valve	AI-S5-309			
4	High Pressure Gas Valve O-Ring	AI-S6-310			
5	Bladder Kit ³				
	Buna-Nitrile	AI-1QT-5-3KT		-SS	-SS
	Butyl	AI-1QT-5-3KT-B		-SS	-SS
	EPR	AI-1QT-5-3KT-E		-SS	-SS
	Fluorocarbon	AI-1QT-5-3KT-V		-SS	-SS
	Hydrin	AI-1QT-5-3KT-H		-SS	-SS
	Low Temp Buna	AI-1QT-5-3KT-L		-SS	-SS
6	Hex Jam Nut	AI-S-305	-SS	-SS	-SS
7	Caution Label	AI-1QT-414			
7	Info Label	AI-1QT-421			
8	Anti-Extrusion Ring				
	Buna-Nitrile	AI-1QT-407	-WS	-WS	-WS
	EPDM	AI-1QT-407-E	-WS	-WS	-WS
	Fluorocarbon	AI-1QT-407-V	-WS	-WS	-WS
9	Fluid Port ⁴	AI-1QT-402	-WS	-SS	-SS
10	Stop Nut	AI-1QT-408	-SS	-SS	-SS
11	Piston	AI-1QT-405	-SS	-SS	-SS
12	Locknut	AI-1QT-403	-WS	-SS	-SS
13	Spacer	AI-1QT-406	-WS	-SS	-SS
14	Spring	AI-1QT-409	-SS	-SS	-SS
15	Poppet	AI-1QT-404	-SS	-SS	-SS
16	Shell (5000 psi)	Not for Sale	N/A	N/A	N/A
17	Metal Back-Up Ring	AI-1QT-412	-SS	-SS	-SS
18	O-Ring				
	Buna-Nitrile	AI-1QT-410			
	EPDM	AI-1QT-410-E			
	Fluorocarbon	AI-1QT-410-V			

Standard Configuration

SA 372 Chrome-moly Steel Shell
 C-1018 and 4130 or 4140 Components
 3/4" NPT Female Fluid Port
 Buna-Nitrile Rubber Components

Optional Configuration (at extra cost)

Resin Coatings, Internal (WS)
 Electroless Nickel Plating, Internal & External (SS)
 Resin Coating – ID, 3 Part Marine Epoxy Paint – OD (XS)
 Stainless Steel Components
 Foreign and Domestic Codes
 Call Factory for Other Options

Dimensions ⁵	
Part Number	Weight
AIQT5100	9.5 lbs

Fluid Port Options	
Fluid Port Type	Designation
3/4" NPT Female	None
Metric Female	-2
1 1/16"-12 SAE Female	-3
Code 61, 3/4" SAE Split Flange	-4
BSPF Female	-7
Other	Call
Special Materials	Call

1 OS-Oil Service, WS- Water Service, SS-Special Service, XS-Extreme Service
 2 Special service accumulator uses a solid protective cap
 3 Bladder kit consists of the following parts: 3, 4, 5, 17, and 18
 4 See Oil Port Configuration for options
 5 Nominal dimensions. Manufacturing variations will occur. Allow +/-2".

1 Gallon 5000 psi Bottom Repairable Accumulator

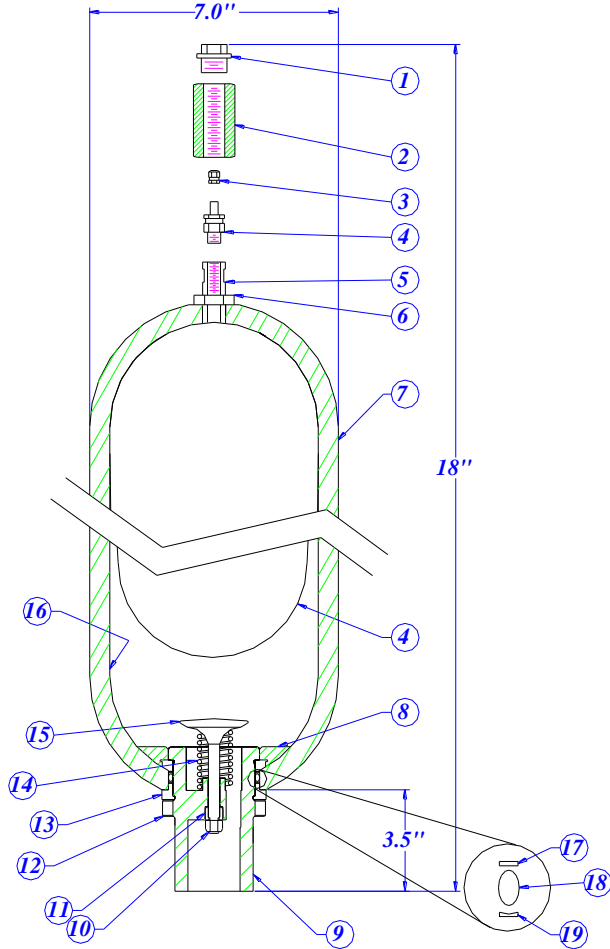

List of Component Parts		Alternate Service ¹			
		Part Number (OS)	WS	SS	XS
1	Safety Cap	AI-S-308		N/A ²	N/A ²
1	Safety Cap O-Ring	AI-S-309		N/A ²	N/A ²
2	Protective Cap	AI-306	-SS	-2-SS	-2-SS
3	Valve cap	AI-S-303			
4	Gas Valve	AI-S6-309			
4	High Pressure Gas Valve O-Ring	AI-S6-310			
5	Bladder Kit ³				
	Buna-Nitrile	AI-1-6-3KT		-SS	-SS
	Butyl	AI-1-6-3KT-B		-SS	-SS
	EPR	AI-1-6-3KT-E		-SS	-SS
	Fluorocarbon	AI-1-6-3KT-V		-SS	-SS
	Hydrin	AI-1-6-3KT-H		-SS	-SS
	Low Temp Buna	AI-1-6-3KT-L		-SS	-SS
6	Hex Jam Nut	AI-S-305	-SS	-SS	-SS
7	Info Label	AI-S-421			
8	Anti-Extrusion Ring				
	Buna-Nitrile	AI-1-6-407	-WS	-WS	-WS
	EPDM	AI-1-6-407-E	-WS	-WS	-WS
	Fluorocarbon	AI-1-6-407-V	-WS	-WS	-WS
9	Fluid Port ⁴	AI-1-6-402	-WS	-SS	-SS
10	Stop Nut	AI-1-408	-SS	-SS	-SS
11	Piston	AI-1-405	-SS	-SS	-SS
12	Locknut	AI-1-5-403	-WS	-SS	-SS
13	Spacer	AI-1-406	-WS	-SS	-SS
14	Spring	AI-1-409	-SS	-SS	-SS
15	Poppet	AI-1-404	-SS	-SS	-SS
16	Shell (5000 psi)	Not for Sale	N/A	N/A	N/A
17	Metal Back-Up Ring	AI-1-412	-SS	-SS	-SS
18	O-Ring				
	Buna-Nitrile	AI-1-410			
	EPDM	AI-1-410-E			
	Fluorocarbon	AI-1-410-V			
19	Rubber O-Ring	AI-1-411			

Standard Configuration

SA 372 Chrome-moly Steel Shell
 C-1018 and 4130 or 4140 Components
 1 1/4" NPT Female Fluid Port
 Buna-Nitrile Rubber Components

Optional Configuration (at extra cost)

Resin Coatings, Internal (WS)
 Electroless Nickel Plating, Internal & External (SS)
 Resin Coating – ID, 3 Part Marine Epoxy Paint – OD (XS)
 Stainless Steel Components
 Foreign and Domestic Codes
 Call Factory for Other Options

Dimensions ⁵	
Part Number	Weight
A15100	36 lbs

Fluid Port Options	
Fluid Port Type	Designation
1 1/4" NPT Female	None
Metric Female	-2
1 3/8"-12 SAE Female	-3
Code 62, 1 1/4" SAE Split Flange	-4
BSPP Female	-7
Other	Call
Special Materials	Call

¹ OS-Oil Service, WS- Water Service, SS-Special Service, XS-Extreme Service
² Special service accumulator uses a solid protective cap
³ Bladder kit consists of the following parts: 3, 4, 5, 17, 18, and 19
⁴ See Oil Port Configuration for options
⁵ Nominal dimensions. Manufacturing variations will occur. Allow +/-2".

2.5-15 Gallon 6000 psi Bottom Repairable Accumulators

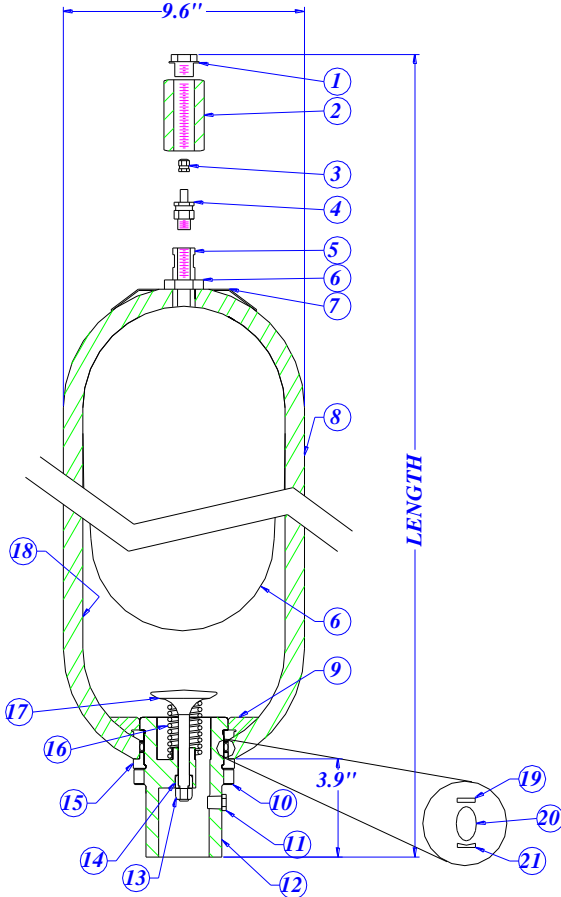

List of Component Parts		Alternate Service ¹		
Description	Part Number (OS)	WS	SS	XS
1	Safety Cap	AI-S-308		N/A ²
1	Safety Cap O-Ring	AI-S-309		N/A ²
2	Protective Cap	AI-306-1	-SS	-4-SS
3	Valve Cap	AI-S-303		
4	High Pressure Gas Valve	AI-S6-309		
4	High Pressure Gas Valve O-Ring	AI-S6-310		
5	Bladder Kit ³			
	Buna-Nitrile	AI-X-6-3KT	-SS	-SS
	Butyl	AI-X-6-3KT-B	-SS	-SS
	EPR	AI-X-6-3KT-E	-SS	-SS
	Fluorocarbon	AI-X-6-3KT-V	-SS	-SS
	Hydrin	AI-X-6-3KT-H	-SS	-SS
	Low Temp Buna	AI-X-6-3KT-L	-SS	-SS
6	Hex Jam Nut	AI-S-305	-SS	-SS
7	Name Plate	AI-S-413		
8	Caution Label	AI-S-421		
9	Anti-Extrusion Ring			
	Buna-Nitrile	AI-S-407	-WS	-WS
	EPDM	AI-S-407-E	-WS	-WS
	Fluorocarbon	AI-S-407-V	-WS	-WS
10	Locknut	AI-S-403	-WS	-SS
11	Bleed Plug			
	1/4" NPT	AI-S-418	-SS	-SS
	7/16"-20 SAE	AI-S-419	-SS	-SS
12	Fluid Port ⁴	AI-S6-402	-WS	-SS
13	Stop Nut	AI-S-408	-SS	-SS
14	Piston	AI-S-405	-SS	-SS
15	Spacer	AI-S6-406	-WS	-SS
16	Spring	AI-S6-409	-SS	-SS
17	Poppet	AI-S-404	-SS	-SS
18	Shell (6000 psi)	Not for Sale	N/A	N/A
19	Metal Back-Up Ring	AI-S-412	-SS	-SS
20	O-Ring			
	Buna-Nitrile	AI-S-410		
	EPDM	AI-S-410-E		
	Fluorocarbon	AI-S-410-V		
21	Rubber Back-Up Ring	AI-S-411		

Standard Configuration

SA 372 Chrome-moly Steel Shell
 2 Piece High Pressure Replaceable Gas Valve
 C-1018 and 4130 or 4140 Components
 2" NPT Female Fluid Port
 Buna-Nitrile Rubber Components

Optional Configuration (at extra cost)

Resin Coatings, Internal (WS)
 Electroless Nickel Plating, Internal & External (SS)
 Resin Coating – ID, 3 Part Marine Epoxy Paint – OD (XS)
 Stainless Steel Components
 Foreign and Domestic Codes
 Call Factory for Other Options

Dimensions ⁵		
Part Number	Length	Weight
A2.56100	22"	118 lbs
A56100	34"	198 lbs
A106100	55"	308 lbs
A156100	79"	468 lbs

Fluid Port Options	
Fluid Port Type	Designation
2" NPT Female	None
1 1/4" NPT Female	-1
Metric Female	-2
1 1/8"-12 SAE Female	-3
Code 62, 1 1/2" SAE Split Flange	-4
BSPF Female	-7
Other	Call
Special Materials	Call

¹ OS-Oil Service, WS- Water Service, SS-Special Service, XS-Extreme Service

² Special service accumulator uses a solid protective cap

³ Insert the size of the accumulator for X, i.e. AI-2.5-6-3KT for a 2.5 gallon bladder kit. Bladder kit consists of the following parts: 3, 4, 5, 19, 20, and 21

⁴ See Oil Port Configuration for options

⁵ Nominal dimensions. Manufacturing variations will occur. Allow +/- .2".

2.5-15 Gallon 6000 psi Top Repairable Accumulators

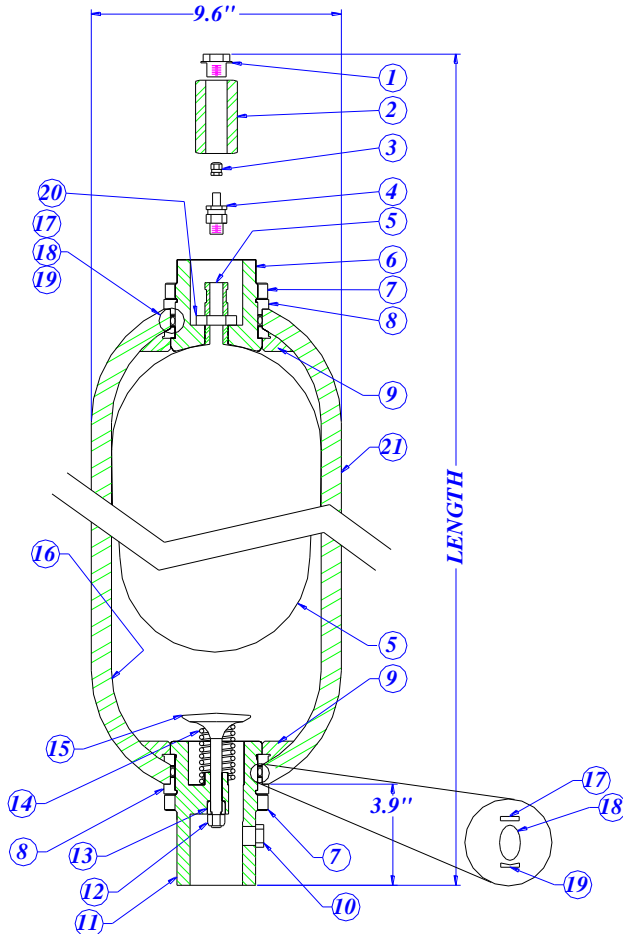

List of Component Parts		Alternate Service ¹			
		Part Number (OS)	WS	SS	XS
1	Safety Cap	AI-S-308		N/A ²	N/A ²
1	Safety Cap O-Ring	AI-S-309		N/A ²	N/A ²
2	Protective Cap	AI-306-1	-SS	-4-SS	-4-SS
3	Valve Cap	AI-S-303			
4	High Pressure Gas Valve	AI-S6-309			
4	High Pressure Gas Valve O-Ring	AI-S6-310			
5	Bladder Kit ³				
	Buna-Nitrile	AI-X-6-3KT		-SS	-SS
	Butyl	AI-X-6-3KT-B		-SS	-SS
	EPR	AI-X-6-3KT-E		-SS	-SS
	Fluorocarbon	AI-X-6-3KT-V		-SS	-SS
	Hydrin	AI-X-6-3KT-H		-SS	-SS
	Low Temp Buna	AI-X-6-3KT-L		-SS	-SS
6	Top Load Adapter	AI-TR6-208	-WS	-SS	-SS
7	Locknut, Qty 2	AI-S-403	-WS	-SS	-SS
8	Spacer, Qty 2	AI-S6-406	-WS	-SS	-SS
9	Anti-Extrusion Ring, Qty 2				
	Buna-Nitrile	AI-S-407	-WS	-WS	-WS
	EPDM	AI-S-407-E	-WS	-WS	-WS
	Fluorocarbon	AI-S-407-V	-WS	-WS	-WS
10	Bleed Plug				
	1/4" NPT	AI-S-418	-SS	-SS	-SS
	7/16"-20 SAE	AI-S-419	-SS	-SS	-SS
11	Fluid Port ⁴	AI-S6-402	-WS	-SS	-SS
12	Stop Nut	AI-S-408	-SS	-SS	-SS
13	Piston	AI-S-405	-SS	-SS	-SS
14	Spring	AI-S6-409	-SS	-SS	-SS
15	Poppet	AI-S-404	-SS	-SS	-SS
16	Shell (6000 psi)	Not for Sale	N/A	N/A	N/A
17	Metal Back-Up Ring, Qty 2	AI-S-412	-SS	-SS	-SS
18	O-Ring, Qty 2				
	Buna-Nitrile	AI-S-410			
	EPDM	AI-S-410-E			
	Fluorocarbon	AI-S-410-V			
19	Rubber Back-Up Ring, Qty 2	AI-S-411			
20	Hex Jam Nut	AI-S-305	-SS	-SS	-SS
21	Caution Label	AI-S-421			

Standard Configuration

SA 372 Chrome-moly Steel Shell
2 Piece High Pressure Replaceable Gas Valve
C-1018 and 4130 or 4140 Components
1 1/4" NPT Female Fluid Port
Buna-Nitrile Rubber Components

Optional Configuration (at extra cost)

Resin Coatings, Internal (WS)
Electroless Nickel Plating, Internal & External (SS)
Resin Coating – ID, 3 Part Marine Epoxy Paint – OD (XS)
Stainless Steel Components
Foreign and Domestic Codes
Call Factory for Other Options

Dimensions⁵

Part Number	Length	Weight
A2.5TR6100	22"	120 lbs
A5TR6100	34"	200 lbs
A10TR6100	55"	310 lbs
A15TR6100	79"	470 lbs

Fluid Port Options

Fluid Port Type	Designation
1 1/4" NPT Female	None
Metric Female	-2
1 7/8"-12 SAE Female	-3
Code 62, 1 1/2" SAE Split Flange	-4
BSPP Female	-7
Other	Call
Special Materials	Call

¹ OS-Oil Service, WS- Water Service, SS-Special Service, XS-Extreme Service

² Special service accumulator uses a solid protective cap

³ Insert the size of the accumulator for X, i.e. AI-2.5-3KT for a 2.5 gallon bladder kit. Bladder kit consists of the following parts: 4,5,18,19,20

⁴ See Oil Port Configuration for options

⁵ Nominal dimensions. Manufacturing variations will occur. Allow +/-0.2".

2.5-15 Gallon 10000 psi Bottom Repairable Accumulators

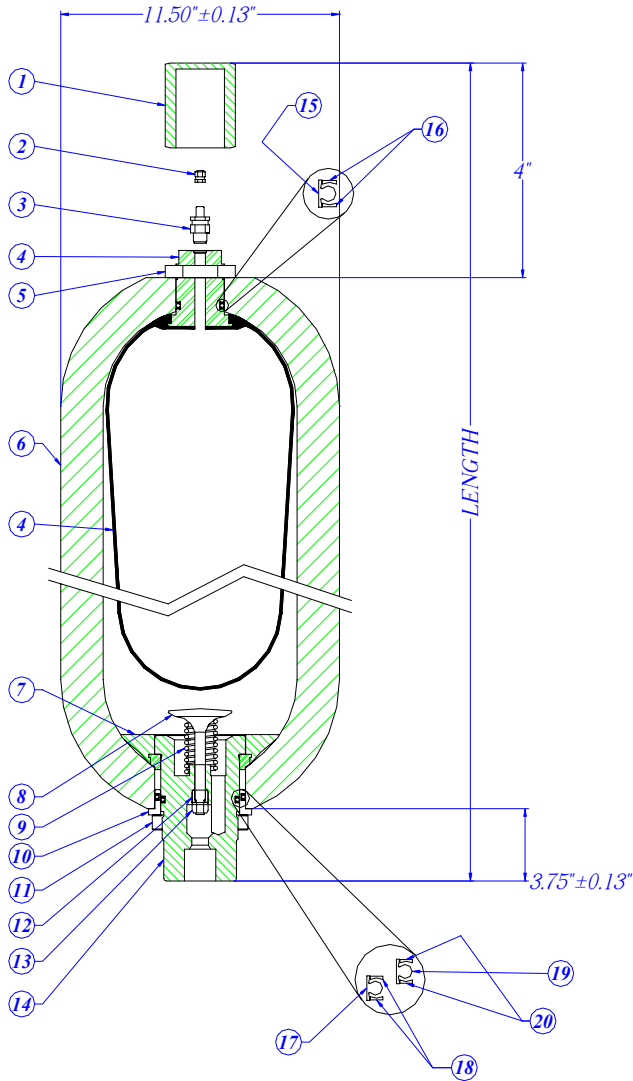

List of Component Parts		
	Description	Part Number
1	Protective Cap	AI-GT5-306-SS
2	Valve Cap	AI-S-303
3	High Pressure Gas Valve	AI-S10-309
4	Bladder Kit ¹	
	Buna-Nitrile	AI-X-10-3KT-SS
	Butyl	AI-X-10-3KT-B-SS
	EPR	AI-X-10-3KT-E-SS
	Fluorocarbon	AI-X-10-3KT-V-SS
	Low Temp Buna	AI-X-10-3KT-L-SS
	Extra Low Temp Buna	AI-X-10-3KT-X-SS
5	Hex Jam Nut	AI-GT5-305-SS
6	Shell (10000 psi)	Not for Sale
7	Anti-Extrusion Ring	
	Buna-Nitrile	AI-S10-407-SS
	EPDM	AI-S10-407-SS-E
	Fluorocarbon	AI-S10-407-SS-V
8	Poppet	AI-S-404-SS
9	Spring	AI-S6-409-SS
10	Spacer	AI-S10-406-SS
11	Locknut	AI-S10-403-SS
12	Piston	AI-S10-405-SS
13	Stop Nut	AI-S10-408-SS
14	Fluid Port ²	AI-S10-402-SS
15	Gas Valve T-Seal	AI-GT5-310
16	Gas Valve Backup O-Ring, Qty 2	AI-GT5-311
17	Fluid Port T-Seal	AI-GT5-410-B
18	Fluid Port Backup O-Ring, Qty 2	AI-GT5-411-B
19	Spacer T-Seal	AI-GT5-410-A
20	Spacer Backup O-Ring, Qty 2	AI-GT5-411-A

Standard Configuration

- SA 372 Chrome-moly Steel Shell
- 2 Piece High Pressure Replaceable Gas Valve
- Stainless Steel Components
- 1" Medium Pressure Female Fluid Port
- Buna-Nitrile Rubber Components
- Resin Coating – ID, 3 Part Marine Epoxy Paint – OD (XS)

Optional Configuration (at extra cost)

- Foreign and Domestic Codes
- Call Factory for Other Options

Dimensions ³		
Part Number	Length	Weight
A2.510100	25"	
A510100	37"	
A1010100	58"	
A1510100	81"	

Fluid Port Options	
Fluid Port Type	Designation
1" Medium Pressure Female	None
Other	Call
Special Materials	Call

¹ Insert the size of the accumulator for X, i.e. AI-2.5-10-3KT-SS for a 2.5 gallon bladder kit. Bladder kit consists of the following parts: 2,3,4,15,16,17,18,19,20
² See Oil Port Configuration for options
³ Nominal dimensions. Manufacturing variations will occur. Allow +/- .2".

2.5-15 Gallon 3000 psi Bottom Repairable Hi-Flow Accumulators

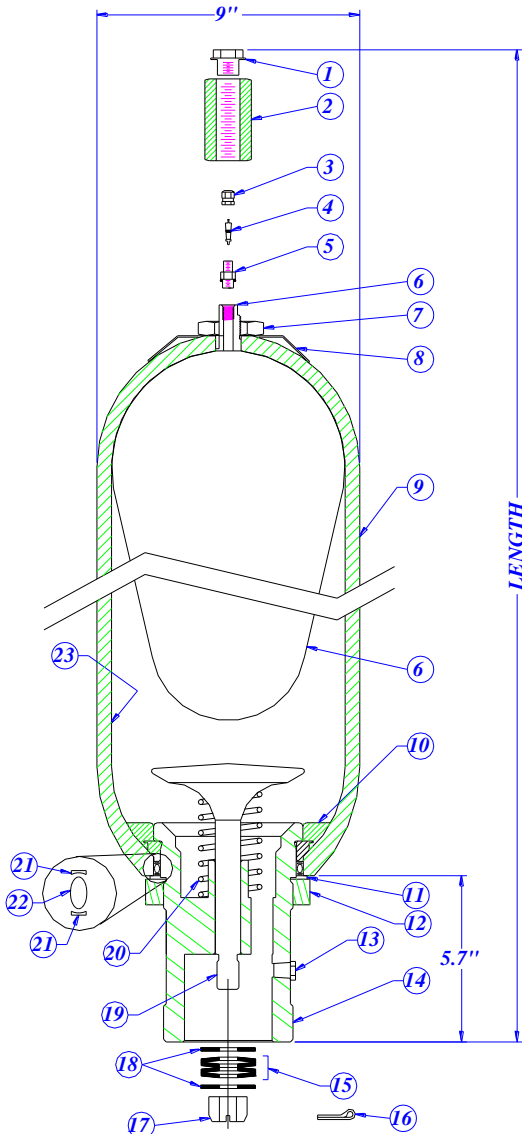

List of Component Parts		Alternate Service ¹			
		Part Number (OS)	WS	SS	XS
1	Safety Cap	AI-S-308		N/A ²	N/A ²
1	Safety Cap O-Ring	AI-S-309		N/A ²	N/A ²
2	Protective Cap	AI-306	-SS	-4-SS	-4-SS
3	Valve Cap	AI-S-303			
4	Valve Core	AI-S-304			
5	GT Gas Valve	AI-GT3-309			
5	Gas Valve O-Ring	AI-GT3-311			
6	Bladder Kit ³				
	Buna-Nitrile	AI-X-3KT		-SS	-SS
	Butyl	AI-X-3KT-B		-SS	-SS
	EPR	AI-X-3KT-E		-SS	-SS
	Fluorocarbon	AI-X-3KT-V		-SS	-SS
	Hydrin	AI-X-3KT-H		-SS	-SS
	Low Temp Buna	AI-X-3KT-L		-SS	-SS
7	Hex Jam Nut	AI-S-305	-SS	-SS	-SS
8	Name Plate	AI-S-413			
9	Caution Label	AI-S-421			
10	Anti-Extrusion Ring	AI-HF-407	-WS	-WS	-WS
11	Spacer	AI-HF-406	-WS	-SS	-SS
12	Locknut	AI-H-403	-WS	-SS	-SS
13	Bleed Plug 1/4" NPT	AI-S-418	-SS	-SS	-SS
14	Oil Port 4"-8 NPT Male				
	No Bleed Plug	AI-HF-402	-WS	-SS	-SS
	w/ Bleed Plug	AI-HF-402-9	-WS	-SS	-SS
	4 1/4" SAE	AI-HF-402-3	-WS	-SS	-SS
15	Belleville Washers, Qty 4	AI-H-416			
16	Cotter Pin	AI-H-421			
17	Castle Nut	AI-H-408			
18	Washers, Qty 2	AI-H-417			
19	Poppet	AI-H-404	-SS	-SS	-SS
20	Spring	AI-H-409	-SS	-SS	-SS
21	Teflon Back-Up Ring	AI-H-411			
22	O-Ring	AI-H-410			
23	Shell (3000 psi)	Not for Sale	N/A	N/A	N/A

Standard Configuration

- SA 372 Chrome-moly Steel Shell
- 2 Piece Replaceable Gas Valve
- C-1018 and 4130 or 4140 Components
- 4" NPT Male Fluid Port, 4 1/4" SAE Male
- Buna-Nitrile Rubber Components

Optional Configuration (at extra cost)

- AN Gas Valve
- Resin Coatings, Internal (WS)
- Electroless Nickel Plating, Internal & External (SS)
- Resin Coating – ID, 3 Part Marine Epoxy Paint – OD (XS)
- Stainless Steel Components
- Foreign and Domestic Codes
- Call Factory for Other Options

Dimensions ⁴		
Part Number	Length	Weight
A2.5H3100	24"	78 lbs
A5H3100	36"	118 lbs
A10H3100	57"	214 lbs
A11H3100	63"	230 lbs
A15H3100	81"	296 lbs

¹ OS-Oil Service, WS- Water Service, SS-Special Service, XS-Extreme Service

² Special service accumulator uses a solid protective cap

³ Insert the size of the accumulator for X, i.e. AI-2.5-3KT for a 2.5 gallon bladder kit. Bladder kit consists of the following parts: 4,5,18,19,20

⁴ Nominal dimensions. Manufacturing variations will occur. Allow +/- .2"

2.5-15 Gallon 3000 psi Top Repairable Hi-Flow Accumulators

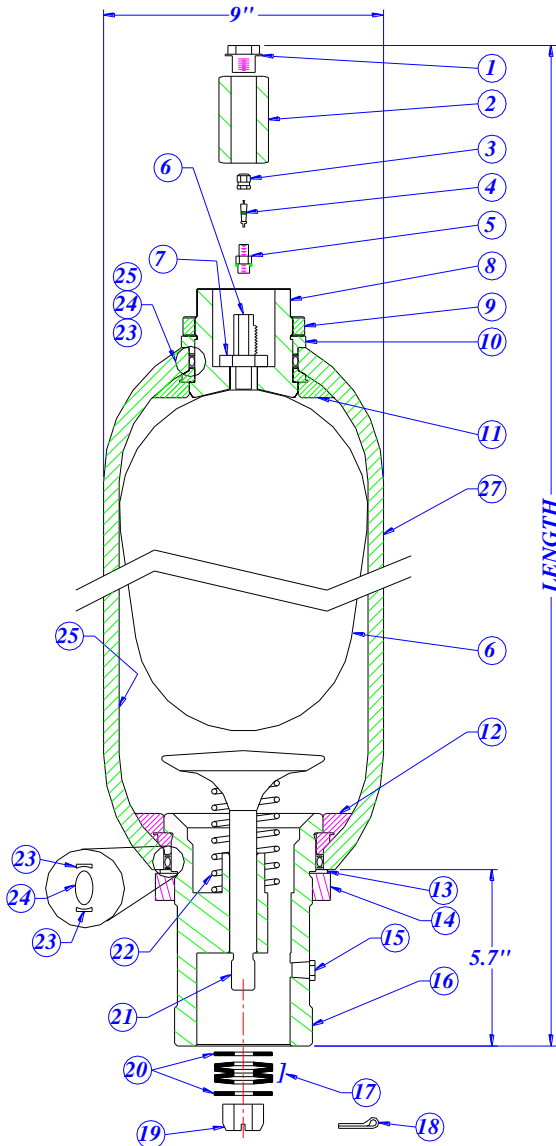

List of Component Parts		Alternate Service ¹		
Description	Part Number (OS)	WS	SS	XS
1	Safety Cap	AI-S-308		N/A ²
1	Safety Cap O-Ring	AI-S-309		N/A ²
2	Protective Cap	AI-306	-SS	-4-SS
3	Valve Cap	AI-S-303		
4	Valve Core	AI-S-304		
5	GT Gas Valve	AI-GT3-309		
5	Gas Valve O-Ring	AI-GT3-311		
6	Bladder Kit ³			
	Buna-Nitrile	AI-X-3KT	-SS	-SS
	Butyl	AI-X-3KT-B	-SS	-SS
	EPR	AI-X-3KT-E	-SS	-SS
	Fluorocarbon	AI-X-3KT-V	-SS	-SS
	Hydrin	AI-X-3KT-H	-SS	-SS
	Low Temp Buna	AI-X-3KT-L	-SS	-SS
7	Hex Jam Nut	AI-S-305	-SS	-SS
8	Top Load Adapter	AI-TR3-208	-WS	-SS
9	Standard Locknut	AI-S-403	-WS	-SS
10	Standard Spacer	AI-S3-406	-WS	-SS
11	Standard Anti-Extrusion Ring	AI-S-407	-WS	-WS
12	Hi-Flow Anti-Extrusion Ring	AI-HF-407	-WS	-WS
13	Hi-Flow Spacer	AI-HF-406	-WS	-SS
14	Hi-Flow Locknut	AI-H-403	-WS	-WS
15	Bleed Plug 1/4" NPT	AI-S-418	-SS	-SS
16	Oil Port 4"-8 NPT Male			
	No Bleed Plug	AI-HF-402	-WS	-SS
	1/4" NPT Bleed Plug	AI-HF-402-9	-WS	-SS
	4 1/4" SAE	AI-HF-402-3	-WS	-SS
17	Belleville Washers, Qty. 4	AI-H-416		
18	Cotter Pin	AI-H-421		
19	Castle Nut	AI-H-408		
20	Washers	AI-H-417		
21	Poppet	AI-H-404	-SS	-SS
22	Spring	AI-H-409	-SS	-SS
23	Teflon Back-Up Ring, Qty 2	AI-H-411		
24	O-Ring	AI-H-410		
25	Shell (3000 psi)	Not For Sale	N/A	N/A
26	Caution Label	AI-S-421		

Standard Configuration

- SA 372 Chrome-moly Steel Shell
- 2 Piece Replacement Gas Valve
- C-1018 and 4130 or 4140 Components
- 4" NPT Female Fluid Port
- Buna-Nitrile Rubber Components

Optional Configuration (at extra cost)

- AN Gas Valve
- Resin Coatings, Internal (WS)
- Electroless Nickel Plating, Internal & External (SS)
- Resin Coating – ID, 3 Part Marine Epoxy Paint – OD (XS)
- Stainless Steel Components
- Foreign and Domestic Codes
- Call Factory for Other Options

Dimensions ⁴		
Part Number	Length	Weight
A2.5HT3100	24"	80 lbs
A5HT3100	36"	120 lbs
A10HT3100	57"	216 lbs
A11HT3100	63"	232 lbs
A15HT3100	81"	298 lbs

¹ OS-Oil Service, WS- Water Service, SS-Special Service, XS-Extreme Service

² Special service accumulator uses a solid protective cap

³ Insert the size of the accumulator for X, i.e. AI-2.5-3KT for a 2.5 gallon bladder kit. Bladder kit consists of the following parts: 3, 4, 5, 6, 23, and 24

⁴ Nominal dimensions. Manufacturing variations will occur. Allow +/-2".

1 Quart 4000 & 5000 psi Gas Bottles

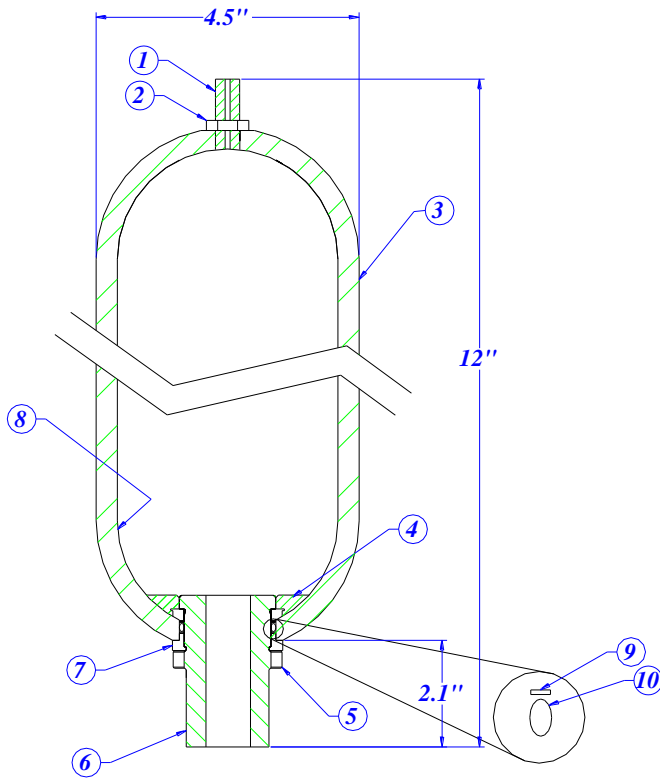

List of Component Parts		Alternate Service ¹		
Description	Part Number (OS)	WS	SS	XS
1 Gas Valve Plug ³	AI-QTR-301		-SS	-SS
2 Jam Nut	AI-S-305	-SS	-SS	-SS
3 Info Label	AI-1QT-421			
3 Caution Label	AI-1QT-414			
4 Anti-Extrusion Ring				
Buna-Nitrile	AI-1QT-407	-WS	-WS	-WS
EPDM	AI-1QT-407-E	-WS	-WS	-WS
Fluorocarbon	AI-1QT-407-V	-WS	-WS	-WS
5 Locknut	AI-1QT-403	-WS	-SS	-SS
6 Gas Port ⁴	AI-QGB3-402	-WS	-SS	-SS
7 Spacer	AI-1QT-406	-WS	-SS	-SS
8 Shell (3000 psi)	Not for Sale	N/A	N/A	N/A
9 Metal Back-Up Ring	AI-1QT-412	-SS	-SS	-SS
10 O-Ring				
Buna-Nitrile	AI-1QT-410			
EPDM	AI-1QT-410-E			
Fluorocarbon	AI-1QT-410-V			

Standard Configuration

SA 372 Chrome-moly Steel Shell
 C-1018 and 4130 or 4140 Components
³/₈"-24 UNF Female Top End
³/₄" NPT Female Fluid Port
 Buna-Nitrile Rubber Components

Optional Configuration (at extra cost)

AN Gas Valve
 Resin Coatings, Internal (WS)
 Electroless Nickel Plating, Internal & External (SS)
 Resin Coating – ID, 3 Part Marine Epoxy Paint – OD (XS)
 Stainless Steel Components
 Foreign and Domestic Codes
 Call Factory for Other Options

Top End Options	
Top End Type	Designation
Plugged	GB
³ / ₈ "-24 UNF Female (GT Valve)	GC
¹ / ₂ "-20 UNF Female (No Valve)	GD
¹ / ₂ "-20 ENF Female (AN Valve)	GE
¹ / ₄ " NPT Female (No Valve)	GF
¹ / ₈ " NPT Female (No Valve)	GG
³ / ₁₆ " NPT Female (No Valve)	GH

Bottom End Options	
Bottom End Type	Designation
³ / ₄ " NPT Female	None
Metric Female	-2
¹ / ₁₆ "-12 SAE Female	-3
Code 61, ³ / ₄ " SAE Split Flange	-4
BSPP Female	-7
Other	Call
Special Materials	Call

1 OS-Oil Service, WS- Water Service, SS-Special Service, XS-Extreme Service
 2 Special service accumulator uses a solid protective cap
 3 See Top End Options for options
 4 See Gas Port Options for options
 5 Nominal dimensions. Manufacturing variations will occur. Allow ⁺/₂".

1 Gallon 3000 psi Gas Bottle
5000 psi also available. Call factory.

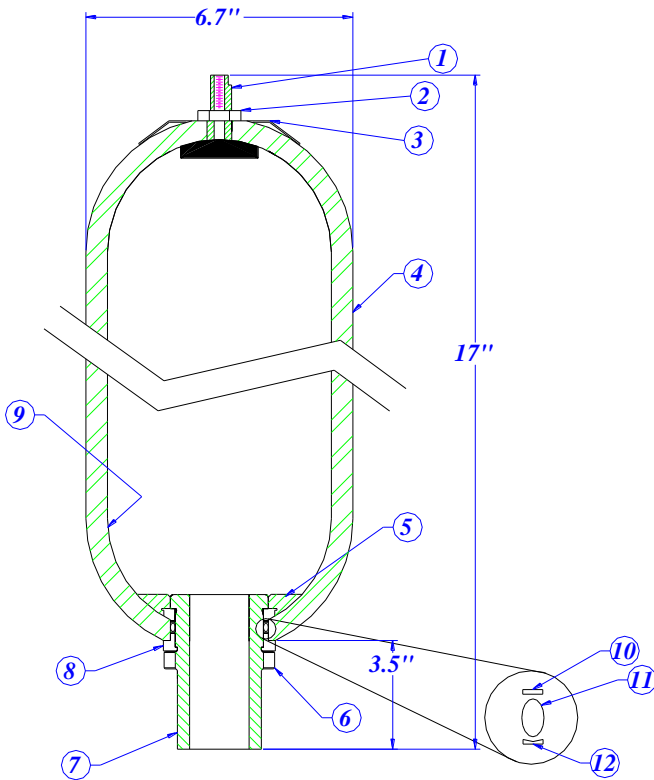

List of Component Parts		Alternate Service ¹		
Description	Part Number (OS)	WS	SS	XS
1 Gas Valve Plug ³	AI-1-R3-301		-SS	-SS
2 Jam Nut	AI-S-305	-SS	-SS	-SS
3 Name Plate	AI-S-413			
4 Caution Label	AI-S-421			
5 Anti-Extrusion Ring				
Buna-Nitrile	AI-1-407	-WS	-WS	-WS
EPDM	AI-1-407-E	-WS	-WS	-WS
Fluorocarbon	AI-1-407-V	-WS	-WS	-WS
6 Locknut	AI-1-403	-WS	-SS	-SS
7 Gas Port ⁴	AI-1-GB3-402	-WS	-SS	-SS
8 Spacer	AI-1-406	-WS	-SS	-SS
9 Shell (3000 psi)	Not for Sale	N/A	N/A	N/A
10 Metal Back-Up Ring	AI-1-412	-SS	-SS	-SS
11 O-Ring				
Buna-Nitrile	AI-1-410			
EPDM	AI-1-410-E			
Fluorocarbon	AI-1-410-V			
12 Rubber Back-Up Ring	AI-1-411			

Standard Configuration

SA 372 Chrome-moly Steel Shell
C-1018 and 4130 or 4140 Components
³/₈"-24 UNF Female Top End
1 ¹/₄" NPT Female Fluid Port
Buna-Nitrile Rubber Components

Optional Configuration (at extra cost)

AN Gas Valve
Resin Coatings, Internal (WS)
Electroless Nickel Plating, Internal & External (SS)
Resin Coating – ID, 3 Part Marine Epoxy Paint – OD (XS)
Stainless Steel Components
Foreign and Domestic Codes
Call Factory for Other Options

Top End Options	
Top End Type	Designation
Plugged	GB
³ / ₈ "-24 UNF Female (GT Valve)	GC
¹ / ₂ "-20 UNF Female (No Valve)	GD
¹ / ₂ "-20 ENF Female (AN Valve)	GE
¹ / ₄ " NPT Female (No Valve)	GF
¹ / ₈ " NPT Female (No Valve)	GG
³ / ₁₆ " NPT Female (No Valve)	GH

Bottom End Options	
Bottom End Type	Designation
1 ¹ / ₄ " NPT Female	None
Metric Female	-2
1 ³ / ₈ "-12 SAE Female	-3
Code 61, 1 ¹ / ₂ " SAE Split Flange	-4
BSPP Female	-7
Other	Call
Special Materials	Call

1 OS-Oil Service, WS- Water Service, SS-Special Service, XS-Extreme Service
2 Special service accumulator uses a solid protective cap
3 See Top End Options for options
4 See Gas Port Options for options
5 Nominal dimensions. Manufacturing variations will occur. Allow ⁺/₂".

2.5-15 Gallon 3000 psi Gas Bottle

6000 psi also available. Call factory.

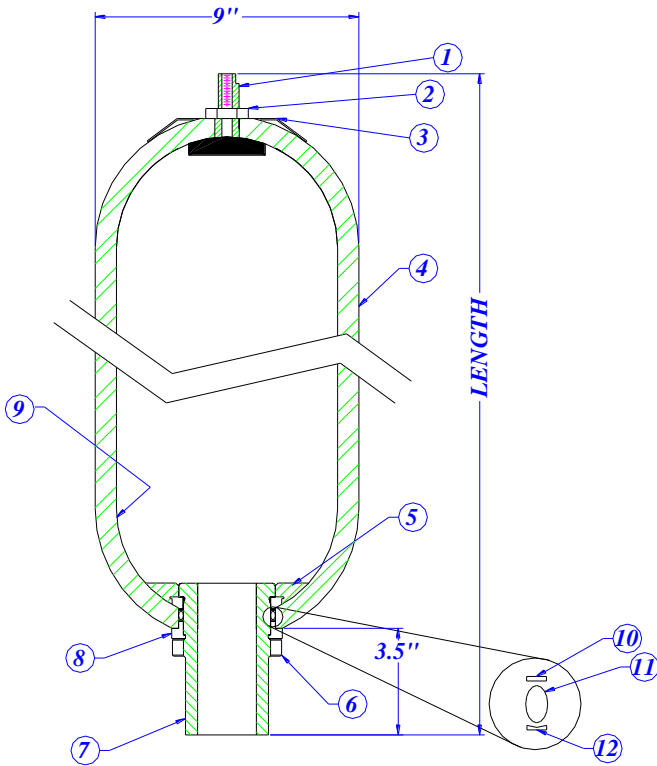

List of Component Parts		Alternate Service ¹		
Description	Part Number (OS)	WS	SS	XS
1 Gas Valve Plug ³	AI-R3-301		-SS	-SS
2 Jam Nut	AI-S-305	-SS	-SS	-SS
3 Name Plate	AI-S-413			
4 Cauton Label	AI-S-421			
5 Anti-Extrusion Ring				
Buna-Nitrile	AI-S-407	-WS	-WS	-WS
EPDM	AI-S-407-E	-WS	-WS	-WS
Fluorocarbon	AI-S-407-V	-WS	-WS	-WS
6 Locknut	AI-S-403	-WS	-SS	-SS
7 Gas Port ⁴	AI-GB3-402	-WS	-SS	-SS
8 Spacer	AI-S3-406	-WS	-SS	-SS
9 Shell (3000 psi)	Not for Sale	N/A	N/A	N/A
10 Metal Back-Up Ring	AI-S-412	-SS	-SS	-SS
11 O-Ring				
Buna-Nitrile	AI-S-410			
EPDM	AI-S-410-E			
Fluorocarbon	AI-S-410-V			
12 Rubber Back-Up Ring	AI-S-411			

Dimensions ⁶		
Part Number	Length	Weight
A2.5GB3100	20"	78 lbs
A5GB3100	32"	118 lbs
A10GB3100	53"	214 lbs
A11GB3100	59"	232 lbs
A15GB3100	77"	298 lbs

Top End Options	
Top End Type	Designation
Plugged	GB
³ / ₈ "-24 UNF Female (GT Valve)	GC
¹ / ₂ "-20 UNF Female (No Valve)	GD
¹ / ₂ "-20 ENF Female (AN Valve)	GE
¹ / ₄ " NPT Female (No Valve)	GF
¹ / ₈ " NPT Female (No Valve)	GG
³ / ₁₆ " NPT Female (No Valve)	GH
2" NPT Female Port ⁵	GI
1 ¹ / ₈ "-12 SAE Female Port ⁵	GJ
1 ¹ / ₄ " NPT Female Port ⁵	GK

Bottom End Options	
Bottom End Type	Designation
2" NPT Female	None
1 ¹ / ₄ " NPT Female	-1
Metric Female	-2
1 ¹ / ₈ "-12 SAE Female	-3
Code 61, 2" SAE Split Flange	-4
Other	Call
Special Materials	Call

Standard Configuration

SA 372 Chrome-moly Steel Shell
 C-1018 and 4130 or 4140 Components
³/₈"-24 UNF Female Top End
 2" NPT Female Fluid Port
 Buna-Nitrile Rubber Components

Optional Configuration (at extra cost)

AN Gas Valve
 Resin Coatings, Internal (WS)
 Electroless Nickel Plating, Internal & External (SS)
 Resin Coating – ID, 3 Part Marine Epoxy Paint – OD (XS)
 Stainless Steel Components
 Foreign and Domestic Codes
 Call Factory for Other Options

¹ OS-Oil Service, WS- Water Service, SS-Special Service, XS-Extreme Service

² Special service accumulator uses a solid protective cap

³ See Top End Options for options

⁴ See Gas Port Options for options

⁵ Uses Top Repairable Design (Not Shown)

⁶ Nominal dimensions. Manufacturing variations will occur. Allow ⁺/₂".

**10, 11, and 15 Gallon 3000 psi
 Patented Float Accumulators**
 6000 psi also available. Call factory.

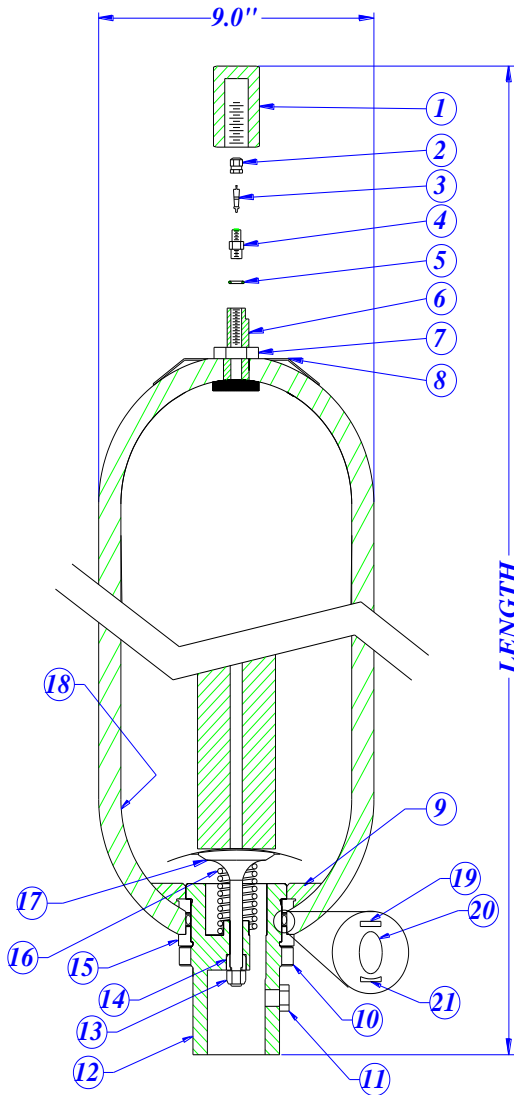

List of Component Parts		
Description	Part Number (XS)	
1	Solid Protective Cap	AI-306-4-SS
2	Valve Cap	AI-S-303
3	Valve Core	AI-S-304
4	GT Gas Valve	AI-GT3-309
5	Gas Valve O-Ring	AI-GT3-310
6	Rubber Coated Valve Stem	AI-R3-302-SS
7	Hex Jam Nut	AI-S-305
8	Name Plate	AI-S-413
9	Anti-Extrusion Ring	
	Buna-Nitrile	AI-S-407-WS
	EPDM	AI-S-407-E-WS
	Fluorocarbon	AI-S-407-V-WS
10	Locknut	AI-S-403-SS
11	Bleed Plug	
	1/4" NPT	AI-S-418-SS
	7/16"-20 SAE	AI-S-419-SS
12	Oil Port ³	AI-S3-402-SS
13	Stop Nut	AI-S-408-SS
14	Piston	AI-S-405-SS
15	Spacer	AI-S3-406-SS
16	Spring	AI-S3-409-SS
17	Poppet Assembly	AI-F-431-SS
18	Shell (3000 psi)	Not for Sale
19	Metal Back-Up Ring	AI-S-412-SS
20	O-Ring	
	Buna-Nitrile	AI-S-410
	EPDM	AI-S-410-E
	Fluorocarbon	AI-S-410-V
21	Rubber Back-Up Ring	AI-S-411

Standard Configuration

SA-372 Chrom-moly Steel Shell
 2 Piece Replaceable Gas Valve
 C-1018 and 4130 or 41040 parts
 2" NPT Female Fluid Port
 Buna-Nitrile Rubber Components

Optional Configuration (at extra cost)

AN Gas Valve
 Resin Coatings, Internal (WS)
 Electroless Nickel Plating, Internal & External (SS)
 Resin Coating – ID, 3 Part Marine Epoxy Paint – OD (XS)
 Stainless Steel Components
 Foreign and Domestic Codes
 Call Factory for Other Options

Dimensions ⁴		
Part Number	Length	Weight
A10F3100	54"	220 lbs
A11F3100	60"	232 lbs
A15F3100	78"	304 lbs

Fluid Port Options	
Fluid Port Type	Designation
2" NPT Female	None
1 1/4" NPT Female	-1
Metric Female	-2
1 1/8"-12 SAE Female	-3
Code 61, 2" SAE 61 Split Flange	-4
Other	Call
Special Materials	Call

¹ OS-Oil Service, WS- Water Service, SS-Special Service
² Special service accumulator uses a solid protective cap
³ See Oil Port Options for configuration options
⁴ Nominal dimensions. Manufacturing variations will occur

1 Quart 3000 & 5000 psi Transfer Barrier Accumulator

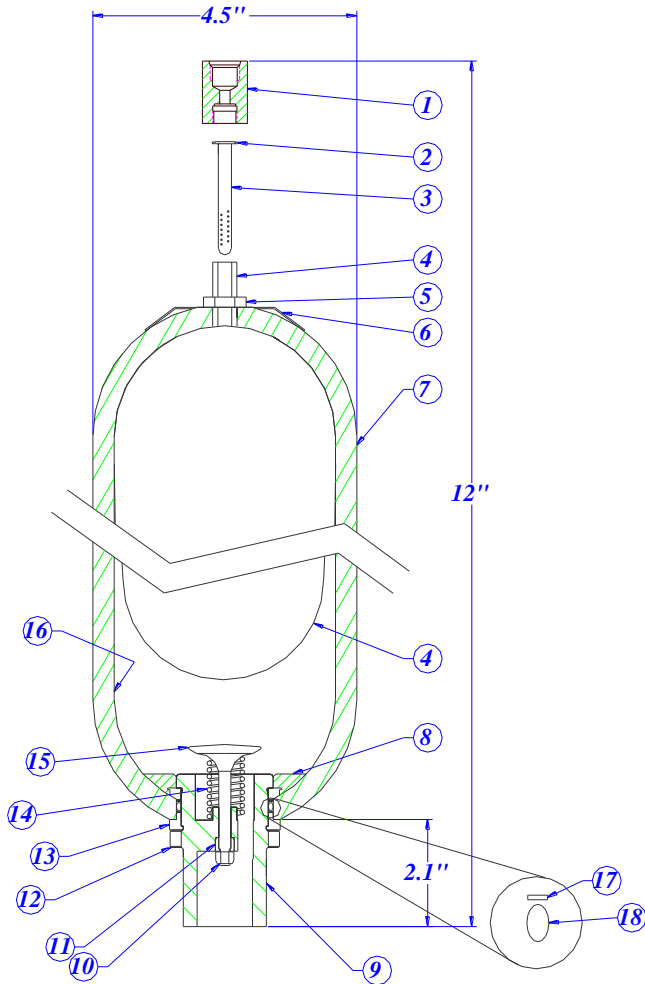

List of Component Parts		Alternate Service ¹		
Description	Part Number (OS)	WS	SS	XS
1	Transfer Barrier Coupler ²	AI-TB-321-C		
2	Transfer Barrier O-Ring	AI-TB-310		
3	Transfer Barrier Tube	AI-TB-320-A		
4	Bladder Kit ³			
	Buna-Nitrile	AI-1QT-TB-3KKT	-SS	-SS
	Butyl	AI-1QT-TB-3KTB	-SS	-SS
	EPR	AI-1QT-TB-3KTE	-SS	-SS
	Fluorocarbon	AI-1QT-TB-3KTV	-SS	-SS
	Hydrin	AI-1QT-TB-3KTH	-SS	-SS
	Low Temp Buna	AI-1QT-TB-3KTL	-SS	-SS
5	Hex Jam Nut	AI-S-305	-SS	-SS
6	Name Plate	AI-1QT-413		
7	Caution Label	AI-1QT-421		
7	Information Label	AI-1QT-414		
8	Anti-Extrusion Ring			
	Buna-Nitrile	AI-1QT-407	-WS	-WS
	EPDM	AI-1QT-407-E	-WS	-WS
	Fluorocarbon	AI-1QT-407-V	-WS	-WS
9	Oil Port ⁴	AI-1QT-402	-WS	-SS
10	Stop Nut	AI-1QT-408	-SS	-SS
11	Piston	AI-1QT-405		
12	Locknut	AI-1QT-403	-WS	-SS
13	Spacer	AI-1QT-406	-WS	-SS
14	Spring	AI-1QT-409		
15	Poppet	AI-1QT-404	-SS	-SS
16	Shell (4000 psi, 5000 psi App 22)	Not for Sale	N/A	N/A
17	Metal Back-Up Ring	AI-1QT-412	-SS	-SS
18	O-Ring			
	Buna-Nitrile	AI-1QT-410		
	EPDM	AI-1QT-410-E		
	Fluorocarbon	AI-1QT-410-V		

Dimensions ⁵	
Part Number	Weight
AIQTTB3100	9.5 lbs
AIQTTB5100	9.5 lbs

Standard Configuration

SA 372 Chrome-moly Steel Shell
 C-1018, 316 SS and 4130 or 4140 Components
 1/2" NPT Coupler
 3/4" NPT Female Fluid Port
 Buna-Nitrile Rubber Components

Optional Configuration (at extra cost)

Resin Coatings, Internal (WS)
 Electroless Nickel Plating, Internal & External (SS)
 Resin Coating – ID, 3 Part Marine Epoxy Paint – OD (XS)
 Stainless Steel Components
 Foreign and Domestic Codes
 Call Factory for Other Options

Coupler Options	
Coupler Type	Designation
3/8" NPT	-A
1/2" NPT	-B
3/4" NPT	-C
1" NPT	-D
1 1/4" NPT	-E
3-Way 1/2" NPT	-F
1/4" NPT	-G
1/2"-20 SAE	-H
3/8" x 3/8" x 1/2" NPT	-I
1/8" NPT	-J
Other	Call

Fluid Port Options	
Fluid Port Type	Designation
3/4" NPT Female	None
Metric Female	-2
1 1/16"-12 SAE Female	-3
BSPF Female	-7
Other	Call
Special Materials	Call

1 OS-Oil Service, WS- Water Service, SS-Special Service, XS-Extreme Service
 2 See Coupler Options for options
 3 Bladder kit consists of the following parts: 4, 17 and 18
 4 See Oil Port Configuration for options
 5 Nominal dimensions. Manufacturing variations will occur. Allow +/-2".

1 Gallon 3000 psi Transfer Barrier Accumulator

5000 psi also available. Call factory.

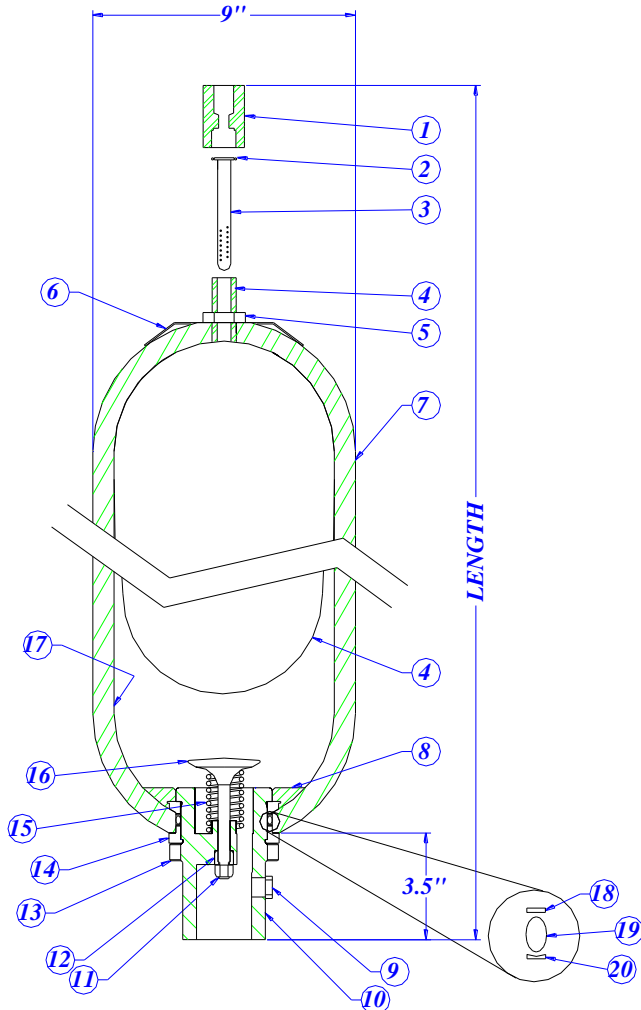

Standard Configuration

SA 372 Chrome-moly Steel Shell
 C-1018 and 4130 or 4140 Components
 1/2" NPT Coupler
 1 1/4" NPT Female Fluid Port
 Buna-Nitrile Rubber Components

Optional Configuration (at extra cost)

Resin Coatings, Internal (WS)
 Electroless Nickel Plating, Internal & External (SS)
 Resin Coating – ID, 3 Part Marine Epoxy Paint – OD (XS)
 Stainless Steel Components
 Foreign and Domestic Codes
 Call Factory for Other Options

List of Component Parts		Alternate Service ¹		
Description	Part Number (OS)	WS	SS	XS
1	Transfer Barrier Coupler ²	AI-TB-321-C		
2	Transfer Barrier O-Ring	AI-TB-310		
3	Transfer Barrier Tube	AI-TB-320-C		
4	Bladder Kit ³			
	Buna-Nitrile	AI-1-TB-3KT	-SS	-SS
	Butyl	AI-1-TB-3KT-B	-SS	-SS
	EPR	AI-1-TB-3KT-E	-SS	-SS
	Fluorocarbon	AI-1-TB-3KT-V	-SS	-SS
	Hydrin	AI-1-TB-3KT-H	-SS	-SS
	Low Temp Buna	AI-1-TB-3KT-L	-SS	-SS
5	Hex Jam Nut	AI-S-305	-SS	-SS
6	Name Plate	AI-1-413		
7	Caution Label	AI-S-421		
8	Anti-Extrusion Ring			
	Buna-Nitrile	AI-1-407	-WS	-WS
	EPDM	AI-1-407-E	-WS	-WS
	Fluorocarbon	AI-1-407-V	-WS	-WS
9	Oil Port ⁴	AI-1-402	-WS	-SS
10	Stop Nut	AI-1-408	-SS	-SS
11	Piston	AI-1-405	-SS	-SS
12	Locknut	AI-1-403	-WS	-SS
13	Spacer	AI-1-406	-WS	-SS
14	Spring	AI-1-409	-SS	-SS
15	Poppet	AI-1-404	-SS	-SS
16	Shell (3000 psi)	Not for Sale		
17	Metal Back-Up Ring	AI-1-412	-SS	-SS
18	O-Ring			
	Buna-Nitrile	AI-1-410		
	EPDM	AI-1-410-E		
	Fluorocarbon	AI-1-410-V		
19	Rubber Back-Up Ring	AI-1-411		

Dimensions ⁵	
Part Number	Weights
AITB3100	32 lbs

Coupler Options	
Coupler Type	Designation
3/8" NPT	-A
1/2" NPT	-B
3/4" NPT	-C
1" NPT	-D
1 1/4" NPT	-E
3-Way 1/2" NPT	-F
1/4" NPT	-G
1/2"-20 SAE	-H
3/8" x 3/8" x 1/2" NPT	-I
1/8" NPT	-J
Other	Call

Fluid Port Options	
Fluid Port Type	Designation
1 1/4" NPT Female	None
Metric Female	-2
1 5/8"-12 SAE Female	-3
Code 61, 1 1/2" SAE Split Flange	-4
BSPP Female	-7
Other	Call
Special Materials	Call

¹ OS-Oil Service, WS- Water Service, SS-Special Service, XS-Extreme Service

² See Coupler Options for options

³ Bladder kit consists of the following parts: 4, 17, 18, and 19

⁴ See Oil Port Configuration for options

⁵ Nominal dimensions. Manufacturing variations will occur. Allow +/- .2".

2.5-15 Gallon 3000 psi Transfer Barrier Accumulator

6000 psi also available. Call factory.

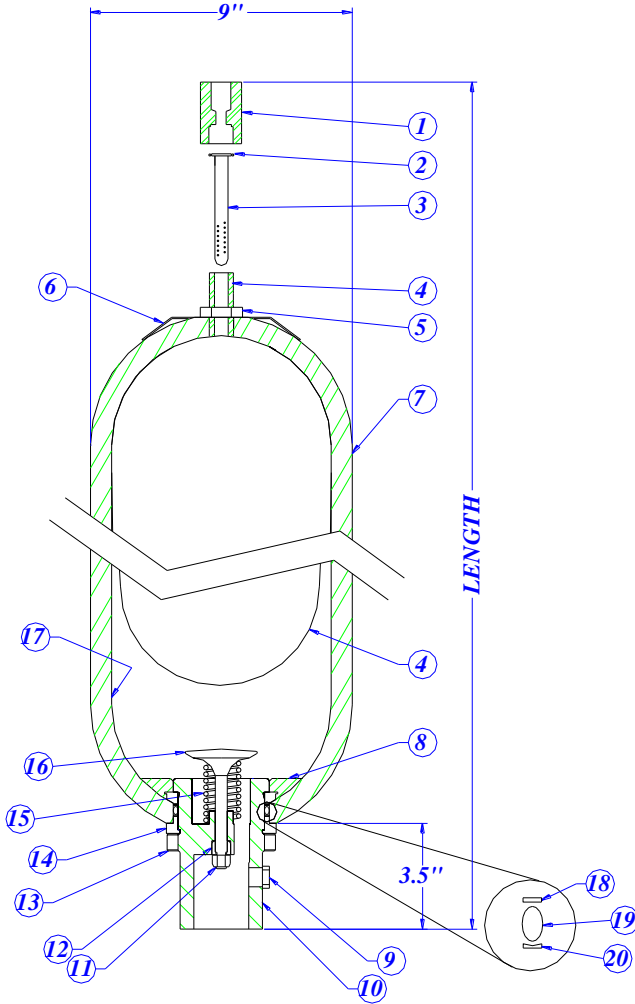

List of Component Parts		Alternate Service ¹		
Description	Part Number (OS)	WS	SS	XS
1	Transfer Barrier Coupler ²			
2	Transfer Barrier O-Ring			
3	TB Tube 2.5-5 Gal., 10-15 Gal.			
4	Bladder Kit ³			
	Buna-Nitrile		-SS	-SS
	Butyl		-SS	-SS
	EPR		-SS	-SS
	Fluorocarbon		-SS	-SS
	Hydrin		-SS	-SS
	Low Temp Buna		-SS	-SS
5	Hex Jam Nut	-SS	-SS	-SS
6	Name Plate			
7	Caution Label			
8	Anti-Extrusion Ring			
	Buna-Nitrile	-WS	-WS	-WS
	EPDM	-WS	-WS	-WS
	Fluorocarbon	-WS	-WS	-WS
9	Bleed Plug NPT, SAE	-SS	-SS	-SS
10	Oil Port ⁴	-WS	-SS	-SS
11	Stop Nut	-SS	-SS	-SS
12	Piston	-SS	-SS	-SS
13	Locknut	-WS	-SS	-SS
14	Spacer	-WS	-SS	-SS
15	Spring	-SS	-SS	-SS
16	Poppet	-SS	-SS	-SS
17	Shell (3000 psi)	Not for Sale		
18	Metal Back-Up Ring	-SS	-SS	-SS
	O-Ring			
	Buna-Nitrile			
	EPDM			
19	Fluorocarbon			
	Rubber Back-Up Ring			

Dimensions ⁵		
Part Number	Length	Weights
A2.5TB3100	21"	78 lbs
A5TB3100	33"	118 lbs
A10TB3100	54"	214 lbs
A11TB3100	60"	232 lbs
A15TB3100	78"	298 lbs

Coupler Options	
Coupler Type	Designation
³ / ₈ " NPT	-A
¹ / ₂ " NPT	-B
³ / ₄ " NPT	-C
3-Way ¹ / ₂ " NPT	-F
¹ / ₄ " NPT	-G
¹ / ₂ "-20 SAE	-H
³ / ₈ " x ³ / ₈ " x ¹ / ₂ " NPT	-I
¹ / ₈ " NPT	-J
Other	Call

Fluid Port Options	
Fluid Port Type	Designation
¹ / ₄ " NPT Female	None
Metric Female	-2
¹ / ₈ "-12 SAE Female	-3
Code 61, 2" SAE Split Flange	-4
BSPF Female	-7
Other	Call
Special Materials	Call

Standard Configuration

SA 372 Chrome-moly Steel Shell
 C-1018 and 4130 or 4140 Components
¹/₂" NPT Coupler
 2" NPT Female Fluid Port
 Buna-Nitrile Rubber Components

Optional Configuration (at extra cost)

Resin Coatings, Internal (WS)
 Electroless Nickel Plating, Internal & External (SS)
 Resin Coating – ID, 3 Part Marine Epoxy Paint – OD (XS)
 Stainless Steel Components
 Foreign and Domestic Codes
 Call Factory for Other Options

¹ OS-Oil Service, WS- Water Service, SS-Special Service, XS-Extreme Service
² See Coupler Options for options
³ Bladder kit consists of the following parts: 4, 17, 18, and 19
⁴ See Oil Port Configuration for options
⁵ Nominal dimensions. Manufacturing variations will occur. Allow +/- .2"

Piston Accumulator Specifications

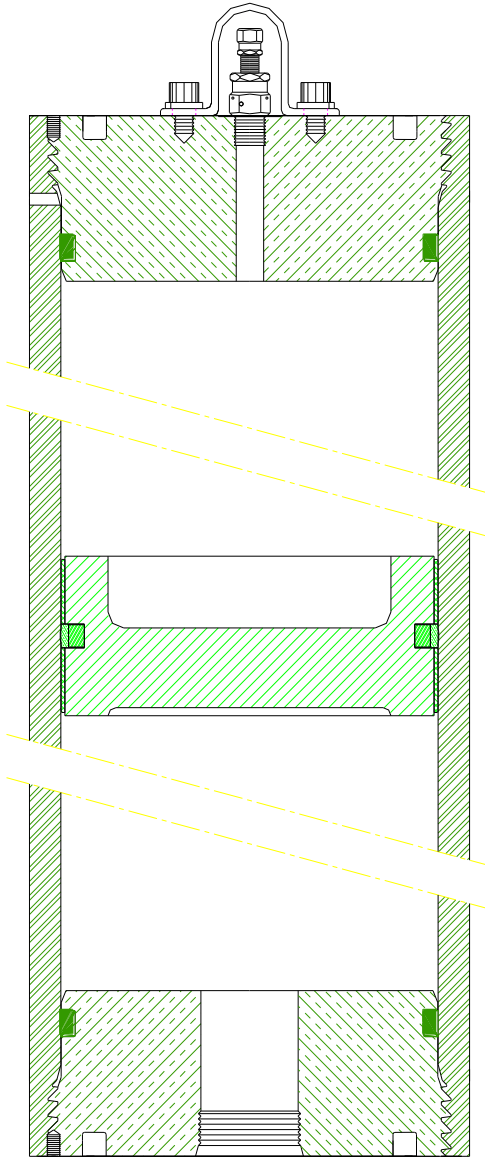

With hundreds of options it is impossible to show the many configurations available with our Piston Accumulators. The following is a list of just some of the many variables. We can size an accumulator to meet your exact requirements or to match an existing unit.

Contact our Engineered Sales Dept for details

Standard Bore Sizes
2.5" To 18.5"

Standard Pressure Range
1,000 PSI To 15,000 PSI

Fluid Capacity
½ Pint To 140 Gallons

Length Range
11" To 146"

Connections
Many sizes and types of fluid connections are available

Custom Designs
We can design the specific unit for your requirements

This is a general cut-away drawing. Actual configuration of Piston Accumulators will vary. Please contact Accumulators, Inc.'s Engineering Department for more details.

Fluid Port Specifications

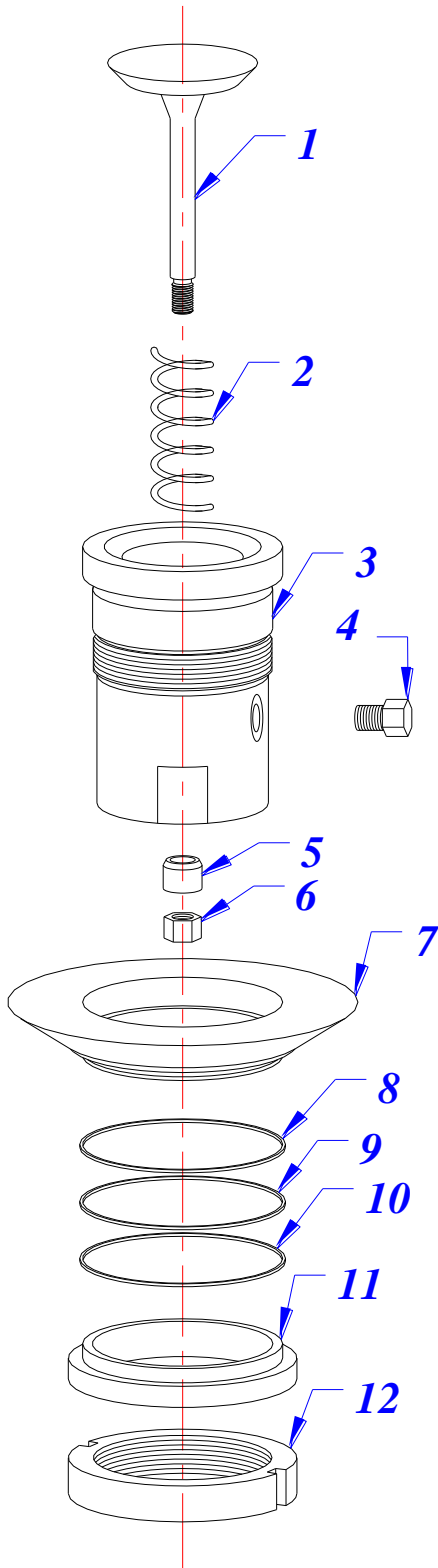

3000 psi Assemblies

Part Description	3000 psi		
	1 Quart	1 Gallon	2 1/2 - 15 Gallon
Oil Port Assembly	AI-1QT-400	AI-1-6-400	AI-S3-400
Plug & Poppet Assembly	AI-1QT-401	AI-1-401	AI-S3-401
Oil Port Plug Only	AI-1QT-402	AI-1-402	AI-S3-402
Poppet	1 AI-1QT-404	AI-1-404	AI-S3-404
Spring	2 AI-1QT-409	AI-1-409	AI-S3-409
Oil Port	3 AI-1QT-402	AI-1-402	AI-S3-402
Bleed Plug	4	--	--
SAE	--	AI-S-418	AI-S-418
NPT	--	AI-S-419	AI-S-419
Piston	5 AI-1QT-405	AI-1-405	AI-S3-405
Stop Nut	6 AI-1QT-408	AI-1-408	AI-S3-408
Anti-Extrusion Ring	7 AI-1QT-407	AI-1-407	AI-S-407
Metal Back-Up Ring	8 AI-1QT-412	AI-1-412	AI-S-412
O-Ring	9 AI-1QT-410	AI-1-410	AI-S-410
Rubber Back-Up Ring	10	AI-1-411	AI-S-411
Spacer	11 AI-1QT-406	AI-1-406	AI-S3-406
Locknut	12 AI-1QT-403	AI-1-403	AI-S-403

5000 psi & 6000 psi Assemblies

Part Description	5000 psi & 6000 psi		
	5000 psi 1 Quart	5000 psi* 1 Gallon	6000 psi 2 1/2 - 15 Gallon
Oil Port Assembly	AI-1QT-400	AI-1-5-400	AI-S6-400
Plug & Poppet Assembly	AI-1QT-401	AI-1-5-401	AI-S6-401
Oil Port Plug Only	AI-1QT-402	AI-1-5-402	AI-S6-402
Poppet	1 AI-1QT-404	AI-1-404	AI-S-404
Spring	2 AI-1QT-409	AI-1-409	AI-S6-409
Oil Port	3 AI-1QT-402	AI-1-5-402	AI-S6-402
Bleed Plug	4	--	--
SAE	--	--	AI-S-418
NPT	--	--	AI-S-419
Piston	5 AI-1QT-405	AI-1-405-S	AI-S-405
Stop Nut	6 AI-1QT-408	AI-1-408	AI-S-408-SS
Anti-Extrusion Ring	7 AI-1QT-407	AI-1-407	AI-S-407-SS
Metal Back-Up Ring	8 AI-1QT-412	AI-1-412	AI-S-412
O-Ring	9 AI-1QT-410	AI-1-410	AI-S-410
Rubber Back-Up Ring	10	AI-1-411	AI-S-411
Spacer	11 AI-1QT-406	AI-1-5-406	AI-S6-406
Locknut	12 AI-1QT-403	AI-1-403	AI-S-403

Thread Options

	1 Quart	1 Gal 3K	1 Gal 6K	Std. 3K	Std 6K
2"-11.5 NPT	--	--	--	None	None
1 1/2"-11 1/2 NPT	--	--	--	-1.5	-5
1 1/4"-11 1/2 NPT	--	None	None	-1	-1
1"-11 1/2 NPT	-1	--	--	--	--
3/4"-14 NPT	None	-1	-1	--	--
1 7/8"-12 SAE	--	--	--	-3	-3
1 5/8"-12 SAE	--	-3	-3	--	--
1 3/16"-12 SAE	--	--	--	-9	-9
1 1/16"-12 SAE	-3	--	--	--	--
Code 61, 3/4" SAE Split Flange	-4	--	--	--	--
Code 61, 1 1/2" SAE Split Flange	--	-4	--	--	--
Code 61, 2" SAE Split Flange	--	--	--	-4	--
Code 62, 1 1/2" SAE Split Flange	--	--	--	--	-4
2" BSPP	--	--	--	-7	--
3/4" BSPP	-7	--	--	--	--
Metric	-2	-2	-2	-2	-2
Other*	Call	Call	Call	Call	Call

*We have hundreds of custom sizes available.

*Some 1 gallon parts are available in 6000 psi designs. Call factory for details.

Gas Valve Specifications

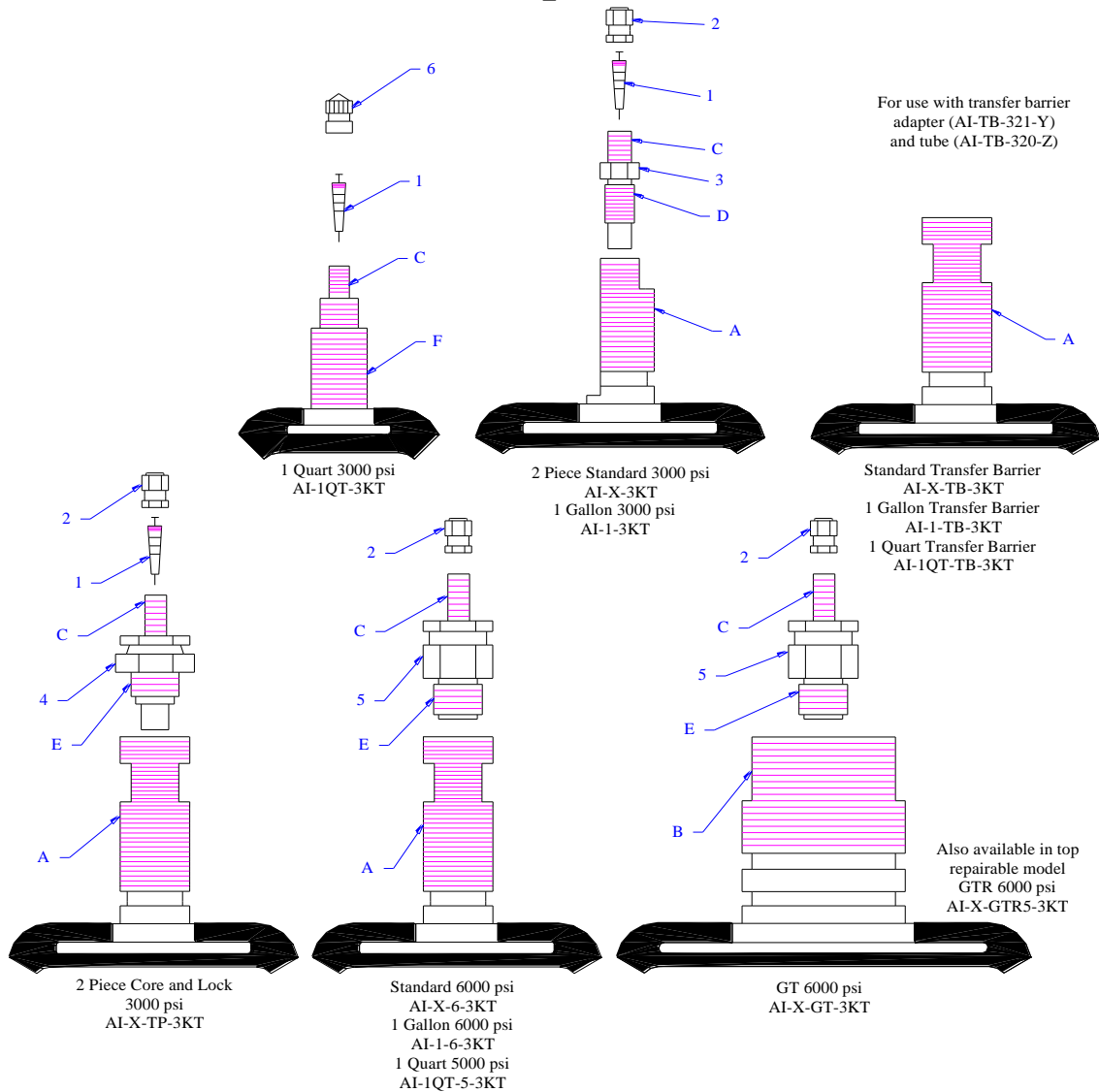

Component Part Numbers

1 Valve Core	AI-S-304
2 Valve Cap	AI-S-303
3 Gas Valve, 3000 psi (Core only)	AI-GT3-309
4 Gas Valve, 3000 psi (Core and Lock) (AN-6287)	AI-S3-309
5 Gas Valve, 6000 psi (Lock only)	AI-S6-309
6 1 Quart Valve Cap	AI-1QT-303
7 Gas Valve, 10000 psi (Lock only, not shown)	AI-S10-309

Thread Specifications

A	7/8"-14 UNF-2A
B	2"-12 UNF-2A
C	.305"-32 UNEF
D	3/8"-24 UNF-2A
E	1/2"-20 UNF-2A
F	5/8"-18 UNF-2A
G	1/2"-20 UNF-2A

The part number under the valve stem references the bladder kit for the valve stem shown. Valve stems are only sold after molding as a bladder. Other special bladders are available upon request. "X" references the size of the accumulator (2.5, 5, 10, 11, or 15 gallon). "Y" references the type of transfer barrier adapter. "Z" references the type of transfer barrier tube.

Other custom designs are available including European styles

Charging and Gauging Kits for 3000 psi Accumulators
 AI-CG3-3KT-SS (3000 psig gauge) and AI-CG3-6KT-SS (6000 psig gauge)

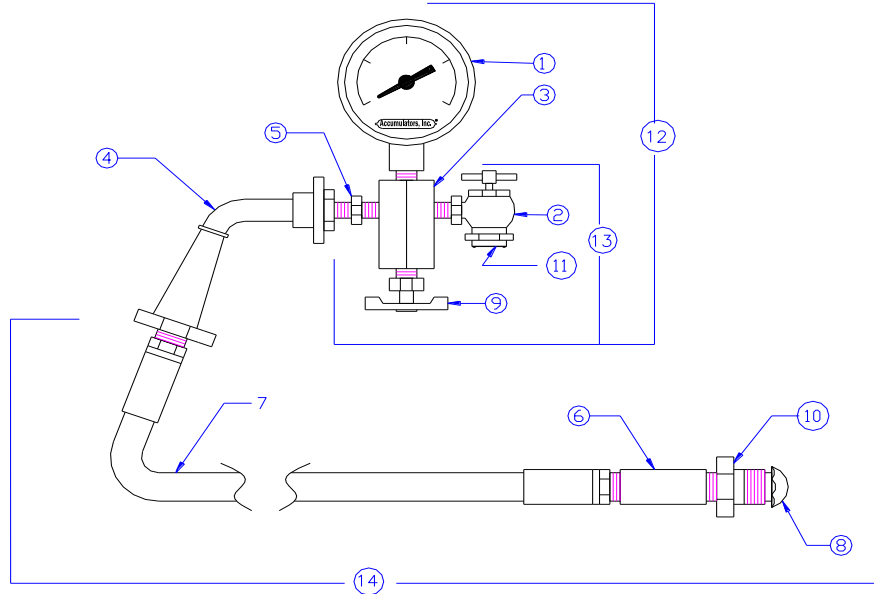

AI-CG3-3KT-SS



AI-CG3-6KT-SS

Sold only in Kit Form: See Page 34 for Kit Components

List of Component Parts		
	Description	Part Number
1	3000 psi Gauge	AI-CG3-001
	6000 psi Gauge	AI-CG6-001-SS
2	Air Chuck	AI-CG-002
3	Adapter Block	AI-CG-003
4	Swivel Connector	AI-CG-004
5	Tank Valve	AI-CG-005
6	Coupler	AI-CG-006
7	Hose	AI-CG-007-SS
8	Gland (Nipple)	AI-CG-008
9	Bleed Valve	AI-CG-009
10	Nut	AI-CG-011
11	Copper Washer	AI-CG-020
12	Gauging & Head Assembly, 3000 psi Gauge	AI-CG3-013
	Gauging & Head Assembly, 6000 psi Gauge	AI-CG6-013
13	Head Assembly, 3000 psi Gauge	AI-CG3-014
	Head Assembly, 6000 psi Gauge	AI-CG6-014
14	Hose Assembly	AI-CG-017-SS
	Valve Core (internal)	AI-S-304

Kit with 3000 psi Gauge	AI-CG3-3KIT-SS
Kit with 6000 psi Gauge	AI-CG3-6KIT-SS

See Page 37 for Kit Components

Charging and Gauging Kits consist of a Hose Assembly, Gauging & Head Assembly, TR adapter, (AI-TR-015) and case (AI-519).

Also Available:

- Complete Accumulator Repair Kits;
- N2 Gas Regulators;
- Special Order C&G Kits with different connections and Different hose lengths.

WARNING! AI-CG3-3KIT-SS and AI-CG3-6KIT-SS Kits are rated for a MAWP Accumulator of 3000 psi. The 6000 psig Gauge is for indication only. Do not use either one on a higher pressure accumulator.

Charging and Gauging Kit for 3000psi to 6000 psi Accumulators

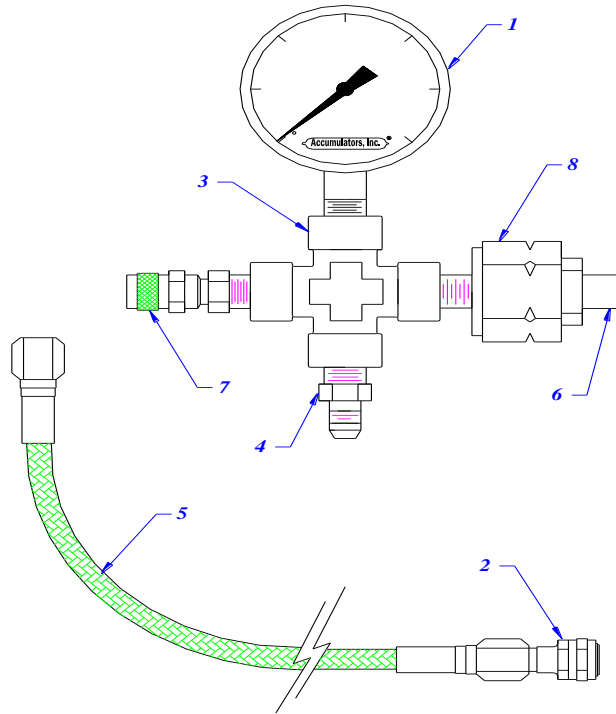

AI-CG6-6KIT-SS

Also Sold in Kit Form: See Page 34 for Kit Components

Full Assembly

List of Component Parts		
	Description	Part Number
	Complete Kit	AI-CG6-6KIT-SS
1	Gauge, 6000 psi	AI-CG6-501-SS
2	Air Chuck	AI-CG6-502-SS
3	Cross, SS	AI-CG6-503-SS
4	J.I.C. Adapter	AI-CG6-506-SS
5	Hose, 8 ft.	AI-CG6-507-SS
6	Cylinder Valve Tube	AI-CG6-508-SS
7	Bleed Valve	AI-CG6-509-SS
8	Cylinder Valve Nut	AI-CG6-511-SS

Hose Assembly

List of Component Parts		
	Description	Part Number
	Head Assembly	AI-CG6-517-SS
4	J.I.C. Adapter	AI-CG6-506-SS
5	Hose, 8 ft.	AI-CG6-507-SS
7	Air Chuck	AI-CG6-502-SS

All materials stainless steel.

Also Available: *Complete Accumulator Repair Kits; *N2 Gas Regulators; *Special Order C&G Kits with different connections and Different hose lengths

Gauging & Head Assembly

List of Component Parts		
	Description	Part Number
	Gauging & Head Ass'y	AI-CG6-513-SS
1	Gauge, 6000 psi	AI-CG6-501-SS
3	Cross, SS	AI-CG6-503-SS
4	J.I.C. Adapter	AI-CG6-506-SS
6	Cylinder Valve Tube	AI-CG6-508-SS
7	Bleed Valve	AI-CG6-509-SS
8	Cylinder Valve Nut	AI-CG6-511-SS

Charging and Gauging Kits consist of a Hose Assembly, Gauging & Head Assembly, TR adapter, (AI-TR-015) and case (AI-519).

Accumulator Accessory Kits

For Charging & Gauging, Maintenance, Repair

AI-TKIT. Complete 3000 psi Maintenance Kit with 3000 psi gauge.
Everything you need to precharge, maintain and repair any 3000 psi accumulator. Includes spare parts

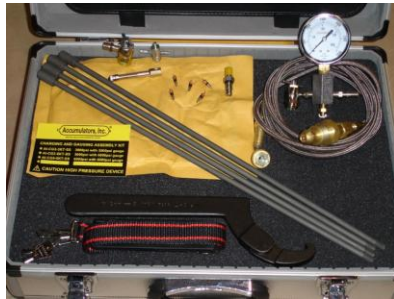

Part No.	Description	Qty.
AI-TR-015	Gas Valve Extension	1
AI-501	Bladder Pull Rod	4
AI-505	Spanner Wrench	1
AI-506	Valve Core Tool 4-way	1
AI-516	Aluminum Tool Case	1
AI-CG-002	Air Chuck	1
AI-GT3-309-KIT	Gas Valve Std SS	1
AI-S-304	Valve Core	5
AI-CG3-000-SS	C&G Assembly 3k psi	1
AI-CG-421	C&G Kit Info Label	1

AI-TKIT-6. Complete 6000 psi Maintenance Kit with 6000 psi gauge
Everything you need to precharge, maintain and repair any 6000 psi accumulator.



Part No.	Description	Qty.
AI-501	Bladder Pull Rod	4
AI-505	Spanner Wrench	1
AI-516	Aluminum Tool Case	1
AI-S6-309	High Pressure Gas Valve 6k psi	1
AI-CG6-550-SS	C&G Assembly 6k psi	1
AI-CG-421	C&G Kit Info Label	1

AI-TKIT1. Deluxe Maintenance Kit, 3000 psi & 6000 psi
Everything you need to precharge, maintain and repair any 3000 psi or 6000 psi accumulator



Part No.	Description	Qty.
AI-TR-015	Gas Valve Extension	1
AI-501	Bladder Pull Rod	4
AI-505	Spanner Wrench	2
AI-506	Valve Core Tool 4-way	1
AI-516	Aluminum Tool Case	1
AI-CG-002	Air Chuck	1
AI-GT3-309-KIT	Gas Valve GT Std SS	2
AI-S-304	Valve Core	5
AI-GT3-311	GT Gas Valve O-ring	5
AI-CG3-000-SS	C&G Assembly 3k psi	1
AI-S6-309	High Pressure Gas Valve 6k	1
AI-CG6-550-SS	C&G Assembly 6k psi	1
AI-511	Accumulator Lifting Hook Assembly	1
AI-515	Gas Valve Tool TR	2
AI-CG-421	C&G Kit Info Label	1

AI-TKITB. Economy Maintenance 3000 psi Kit with 3000 psi gauge
Everything you need to precharge, maintain and repair any 3000 psi accumulator



Part No.	Description	Qty.
AI-TR-015	Gas Valve Extension	1
AI-501	Bladder Pull Rod	4
AI-505	Spanner Wrench	1
AI-506	Valve Core Tool 4-way	1
AI-519	19" Tool Case	1
AI-CG3-000-SS	C&G Assembly 3k psi	1
AI-CG-421	C&G Kit Info Label	1

AI-CG3-3KT-SS. Charging & Gauging 3000 psi Kit with 3000 psi gauge
Everything you need to precharge any 3000 psi accumulator



Part No.	Description	Qty.
AI-TR-015	Gas Valve Extension	1
AI-517	C&G Case	1
AI-CG6-000-SS	C&G Assembly 3k psi with 6KSI Gauge	1
AI-CG-421	C&G Kit Info Label	1

AI-CG3-6KT-SS. Charging & Gauging 3000 psi Kit with 6000 psi gauge
Everything you need to precharge any 3000 psi accumulator



Part No.	Description	Qty.
AI-TR-015	Gas Valve Extension	1
AI-517	C&G Case	1
AI-CG3-000-SS	C&G Assembly 3k psi	1
AI-CG-421	C&G Kit Info Label	1

AI-CG6-6KT-SS. Charging & Gauging 6000 psi Kit with 6000 psi gauge
Everything you need to precharge any 6000 psi accumulator



Part No.	Description	Qty.
AI-520	16" C&G Case	1
AI-CG6-550-SS	C&G Assembly 6k psi	1
AI-CG-421	C&G Kit Info Label	1

Permanent Mount Pressure Monitor

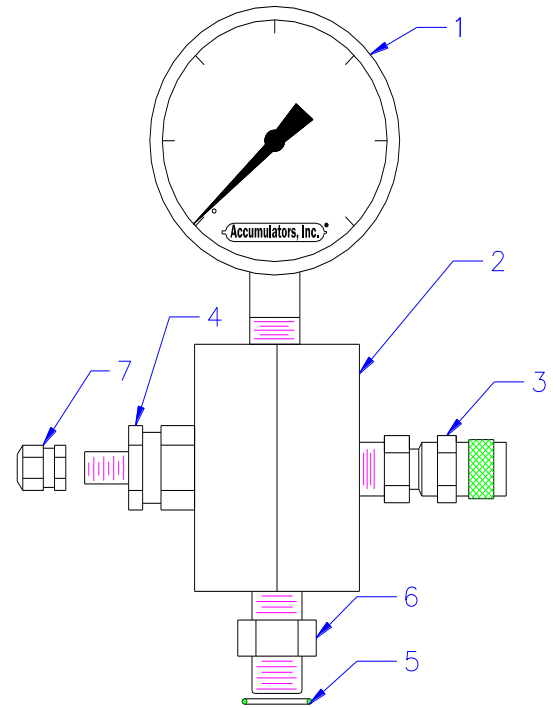
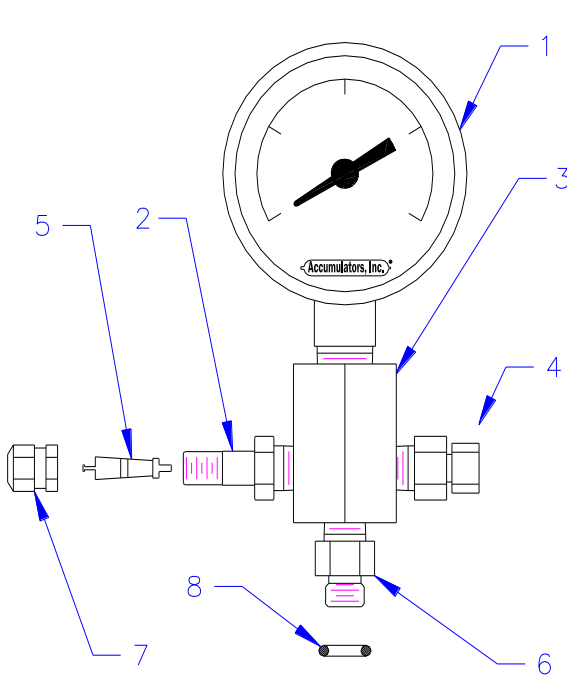

3000 psi Permanent Mount Pressure Monitor
 AI-PM3-000

List of Component Parts		
	Description	Part Number
1	Gauge, 3000 psig Standard	AI-CG3-001
	Gauge, 3000 psig Liquid Filled	AI-CG3-001-L
	Gauge, 3000 psig Digital NEW	AI-CG3-001-D
2	Tank Valve	AI-CG-005
3	Pressure Monitor Block	AI-PM3-003
4	Bleed Valve	AI-PM3-009
5	Valve Core	AI-S-304
6	Pressure Monitor Bushing	AI-PM3-033
7	Valve Cap	AI-S-303
8	O-Ring	AI-GT3-311

6000 psi Permanent Mount Pressure Monitor
 AI-PM6-000-SS

List of Component Parts		
	Description	Part Number
1	Gauge, 6000 psig Standard	AI-CG6-501-SS
	Gauge, 6000 psig Liquid Filled	AI-CG6-501-SS-L
	Gauge, 6000 psig Digital NEW	AI-CG6-501-D-SS
2	Cross, SS	AI-CG6-503-SS
3	Bleed Valve	AI-CG6-509-SS
4	High Pressure Gas Valve	AI-S6-309
5	O-Ring	AI-S6-310
6	Pressure Monitor Bushing	AI-PM6-033-SS
7	Valve Cap	AI-S-303

Note: These units are intended to be mounted permanently on the valve stem of the accumulator to monitor hydraulic system pressure. Nitrogen pre-charge may only be measured when hydraulic line pressure is zero (0) psig.

Mounting Hardware: U-Bolt Kits

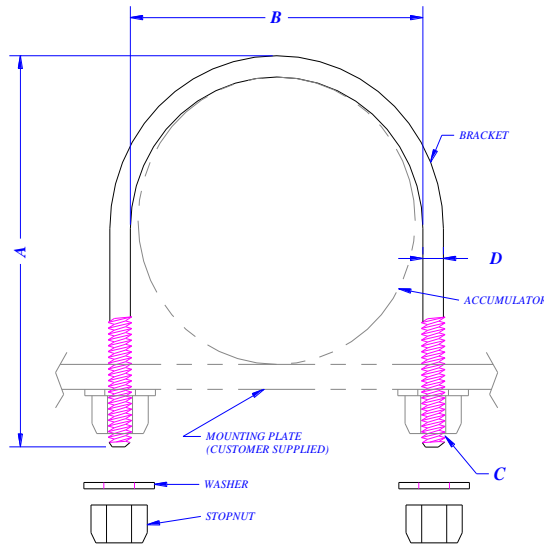

Description	Part Number Standard (Carbon Steel)	Part Number Rubber Coated NEW	Part Number Stainless Steel	Part Number Rubber Coated SS NEW	Part Number Teflon Coated	U-Bolts per Kit	A in.	B in.	C in.	D in.
1 Qt, 3000 & 5000	AI-1QT-507-KIT	AI-1QT-507-KIT-RUB	AI-1QT-507-KIT-SS	AI-1QT-507-KIT-SS-RUB	AI-1QT-507-KIT-T	1	6	4.5	2 x ³ / ₈ -16 UN	0.3
1 Quart Washer	AI-1QT-509	AI-1QT-509	AI-1QT-509-SS	AI-1QT-509-SS	AI-1QT-509-T					
1 Quart Stop Nut	AI-1QT-508	AI-1QT-508	AI-1QT-508-SS	AI-1QT-508-SS	AI-1QT-508-T				³ / ₈ -16 UN	
1 Gallon, 3000 psi	AI-1-507-KIT	AI-1-507-KIT-RUB	AI-1-507-KIT-SS	AI-1-507-KIT-SS-RUB	AI-1-507-KIT-T	1	10	6.8	3 x ¹ / ₂ -13 UN	0.5
2 1/2 Gallon, 3000 psi	AI-2.5-507-KIT	AI-2.5-507-KIT-RUB	AI-2.5-507-KIT-SS	AI-2.5-507-KIT-SS-RUB	AI-2.5-507-KIT-T	1	12.3	9.4	3.5 x ¹ / ₂ -13 UN	0.5
5-15 Gallon, 3000 psi	AI-507-KIT	AI-507-KIT-RUB	AI-507-KIT-SS	AI-507-KIT-SS-RUB	AI-507-KIT-T	2	12.3	9.4	3.5 x ¹ / ₂ -13 UN	0.5
1 Gallon, 6000 psi	AI-1-6-507-KIT	AI-1-6-507-KIT-RUB	AI-1-6-507-KIT-SS	AI-1-6-507-KIT-SS-RUB	AI-1-6-507-KIT-T	1	10.6	7.3	3 x ¹ / ₂ -13 UN	0.5
2 1/2 Gallon, 6000 psi	AI-2.5-6-507-KIT	AI-2.5-6-507-KIT-RUB	AI-2.5-6-507-KIT-SS	AI-2.5-6-507-KIT-SS-RUB	AI-2.5-6-507-KIT-T	1	13	10	3.5 x ¹ / ₂ -13 UN	0.5
5-15 Gallon, 6000 psi	AI-S6-507-KIT	AI-S6-507-KIT-RUB	AI-S6-507-KIT-SS	AI-S6-507-KIT-SS-RUB	AI-S6-507-KIT-T	2	13	10	3.5 x ¹ / ₂ -13 UN	0.5
1-15 Gal. Washer	AI-509	AI-509	AI-509-SS	AI-509-SS	AI-509-T					
1-15 Gal. Stop Nut	AI-508	AI-508	AI-508-SS	AI-508-SS	AI-508-T				¹ / ₂ -13 UN	

Note: All mounting U-Bolts are sold in kit form with the appropriate elastic stop nuts and washers. All standard units are zinc plated carbon steel. Rubber Coated units are Carbon or Stainless Steel, shrunk-fit with Buna-Nitrile rubber. DuPont™ Teflon® coated units are carbon steel with *teflon* spray coating. Consult the factory for details.

OTHER CUSTOM DESIGNS, SIZES AND COATINGS ARE AVAILABLE. Contact Sales Dept. for details

Dimensions are nominal and may vary due to manufacturing tolerances.

It is recommended that you have the bolt on-hand when drilling mounting plate

Mounting Hardware: Bases (“L” Shaped Bracket)

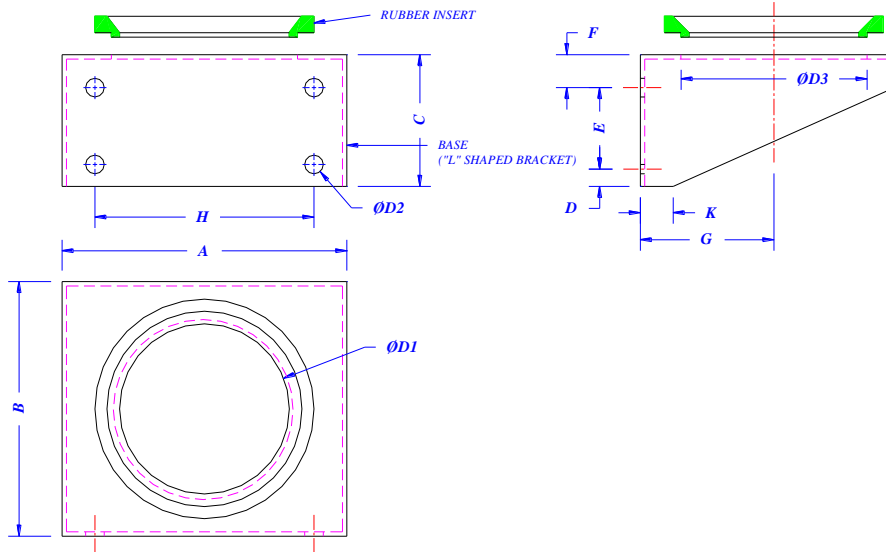

Dimensions in inches

Description	Part Number	A	B	C	D	D1	D2	D3	E	F	G	H
1 Quart 3000 & 5000 psi Base	AI-1QT-512	7.9	6.9	3.5	0.7	4.3	0.4	4.7	1.6	1.2	3.7	5.5
1 Quart Stainless Steel Base	AI-1QT-512-SS	7.9	6.9	3.5	0.7	4.3	0.4	4.7	1.6	1.2	3.7	5.5
1 Gallon 3000 & 6000 psi Base	AI-1-512	10.2	8.9	3.9	1.0	4.3	0.7	4.7	1.6	1.4	3.6	7.9
1 Gallon Stainless Steel Base	AI-1-512-SS	10.2	8.9	3.9	1.0	4.3	0.7	4.7	1.6	1.4	3.6	7.9
1 QT and 1 G Rubber Insert Replacement	AI-1QT-513					4.3		4.7				
2 1/2-15 Gallon 3000 psi Base	AI-S-512	10.2	8.9	3.9	1.0	6.3	0.7	6.7	1.6	1.4	4.8	7.9
2 1/2-15 Gallon 3000 Stainless Steel Base	AI-S-512-SS	10.2	8.9	3.9	1.0	6.3	0.7	6.7	1.6	1.4	4.8	7.9
2 1/2-15 Gallon 6000 psi Base	AI-S6-512	10.2	9.4	3.9	1.0	7.9	0.7	6.7	1.6	1.4	5.3	7.9
2 1/2-15 Gallon 6000 Stainless Steel Base	AI-S6-512-SS	10.2	9.4	3.9	1.0	7.9	0.7	6.7	1.6	1.4	5.3	7.9
2 1/2-15 Gallon Rubber Insert Replacement	AI-S-513					6.3		4.7				

Note: All mounting bases are sold in kit form and include the rubber insert. Mounting bolts are not included. Mounting collars sold separately. Replacement rubber inserts may be purchased separately. Standard Mounting bases are zinc plated carbon steel. Stainless steel units are 300 series stainless.

Dimensions are nominal and may vary due to manufacturing tolerances.

Cathodic Isolation: These rubber lined bases can be used in conjunction with our rubber lined Mounting Collars for the complete electrical isolation of the accumulator

Mounting Hardware: Collars (Clamp)

1 Quart and 1 Gallon
 Fig. 1

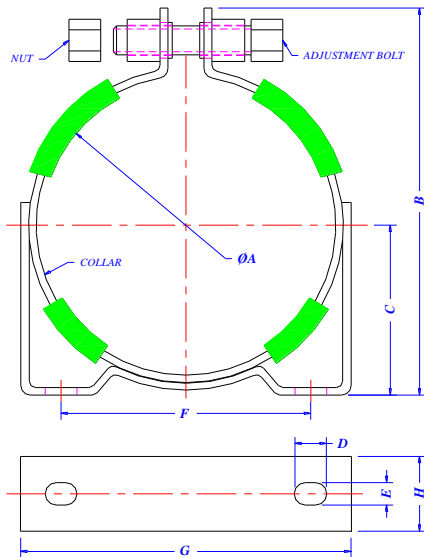

2.5-15 Gallon
 Fig. 2

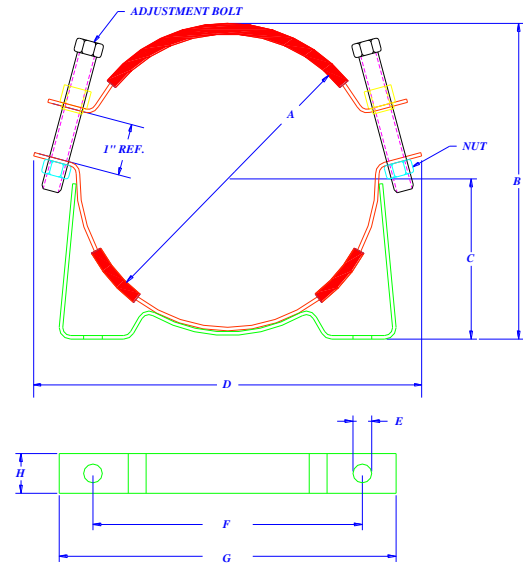

Dimensions in inches

Description	Fig	Part Number Zinc Plated	Part Number Stainless NEW	A	B	C	D	E	F	G	H
1 Quart Collar, 3000 & 5000 psi	1	AI-1QT-511	AI-1QT-511-SS	4.7	6.6	2.7	0.5	0.4	3.9	5.6	1.2
1 Gallon Collar, 3000 psi	1	AI-1-511	AI-1-511-SS	6.9	8.8	3.9	0.5	0.4	6.3	7.6	1.3
1 Gallon Collar, 6000 psi	1	AI-1-6-511	AI-1-6-511-SS	7.3	9.8	4.3	0.5	0.4	6.3	8.4	1.3
2.5-15 Gallon Collar, 3000 psi	2	AI-S-511	AI-S-511-SS	8.9	9.6	4.7	12.8	0.6	8.5	10.6	1.3
2.5-15 Gallon Collar, 6000 psi	2	AI-S6-511	AI-S6-511-SS	9.5	10.3	5.3	13	0.6	8.5	10.6	1.3

Note: Mounting collars are sold in kit form, including the appropriate adjustment bolts and rubber cushions. Mounting bolts are not included. Standard Collars are plated with zinc. Stainless Steel collars are 300 series stainless. Mounting bases sold separately.

Call factory for other special order options.

Dimensions are nominal and may vary due to manufacturing tolerances.

Mounting Brackets: Collars and Bases for AccuMight®

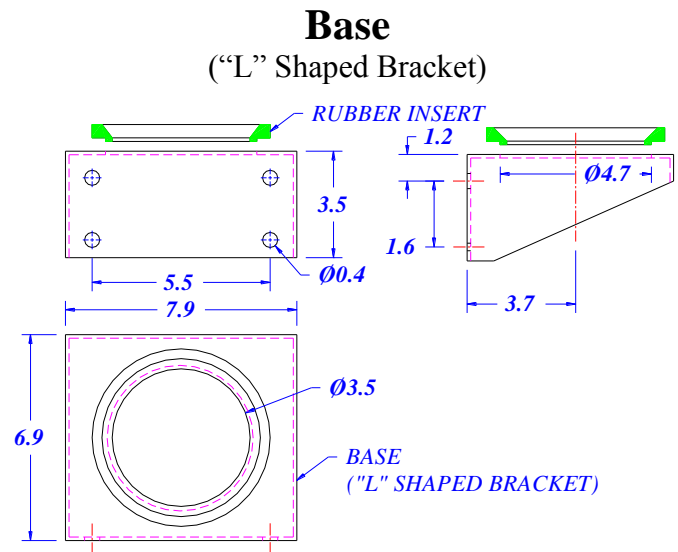
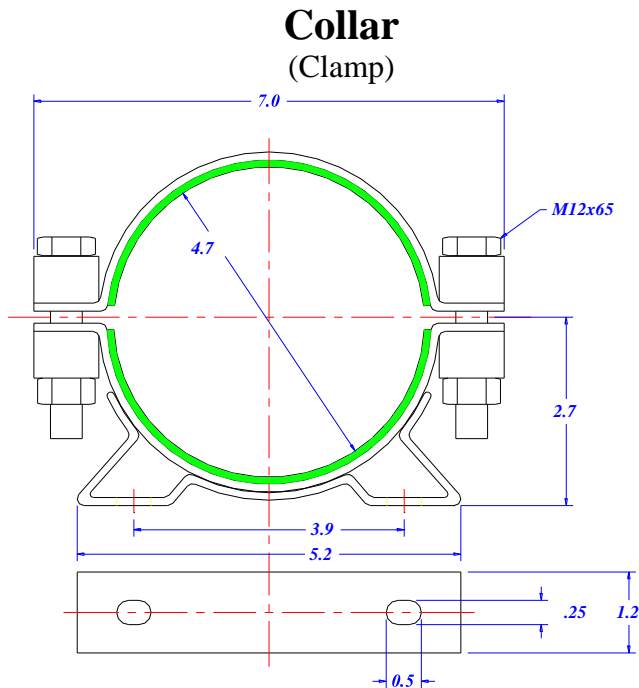

Description	Part Number
90-150 ci AccuMight Collar	AM-511
30 ci AccuMight Collar	AM-514
20 ci AccuMight Collar	AM-516
6 ci AccuMight Collar	AM-515

Description	Part Number
30-150 ci AccuMight Base	AM-512
Rubber Insert for AccuMight Base	AM-513

Note: AccuMight collars are sold in kit form with the appropriate adjustment bolts and rubber cushions. AccuMight bases are sold in kit form and include the rubber insert. Mounting bolts are not included. Replacement rubber inserts may be purchased separately. Collar and bases sold separately. Collars and bases are zinc plated.

Call factory for other special order options including stainless.

Dimensions may vary due to manufacturing tolerances.

Accumulator Repair Tools

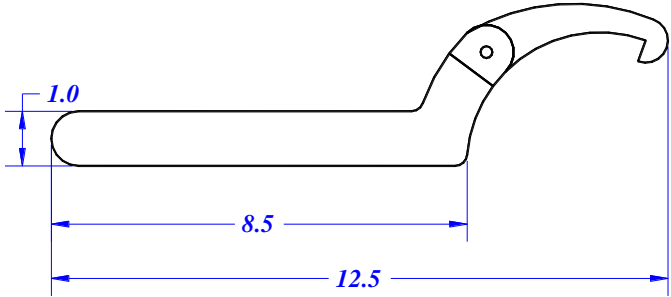
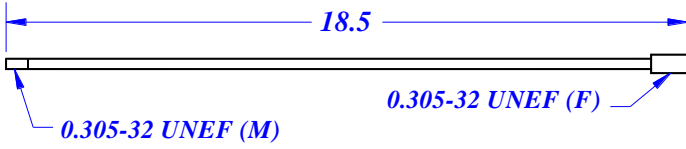
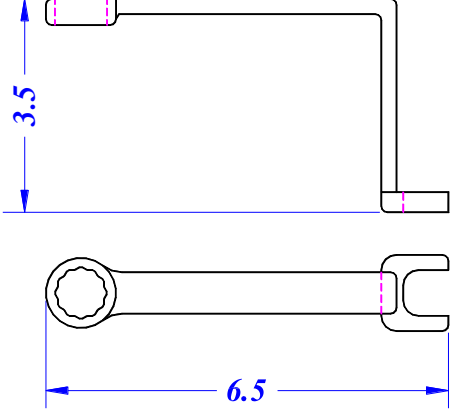
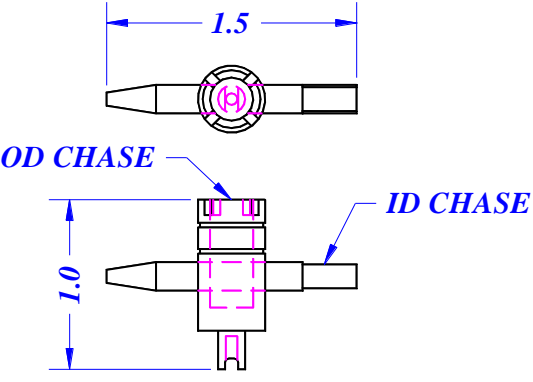
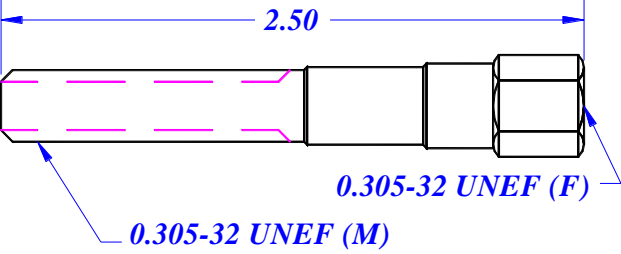
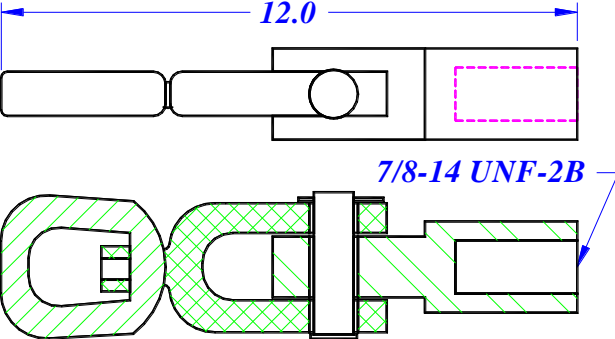
Bladder Pull Rod			Spanner Wrench			
Part Number	For Sizes	Description	Part Number: AI-505			
AI-501	1qt-2.5 Gallon	1 pc kit				
AI-502	5 Gallon	2 pc kit				
AI-503	10-11 Gallon	3 pc kit				
AI-504	15 Gallon	4 pc kit				
			<h3>TR6 Gas Valve Tool</h3> Part Number: AI-515 (2 pc set) 			
<h3>Valve Core Tool</h3> Part Number: AI-506 			<h3>Gas Valve Extension, 3K</h3> Part Number: AI-TR-015 		<h3>Accumulator Lifting Hook Assembly</h3> Part Number: AI-511 	

**Most of these parts are available in one of our
 Accumulator Accessory Kits.**

See the Accumulator Accessories Section. Page 31

Accumulator Safety Block

For Isolation and Emergency Shut-Off

The **Accumulator Safety Block** is a multifunctional valve placed between the hydraulic accumulator and the operating system. Our modular design permits versatility for mounting and a host of connection options for all hydraulic accumulators. The safety block allows for isolation of the Accumulator for maintenance or system testing. Additionally, it can function as an emergency shut-off device or pressure relief valve to protect from over-pressurization and system failure. Accumulator pressure and volume can also be safely released through the safety block's **Manual OR Solenoid** bleed valve.

Selection Chart. Select the Bleed Valve type, Accumulator Side Connection and Discharge Side Connection types to determine Part Number.

Safety Block	Bleed Valve	Description	Accumulator Side Connection	Discharge Side Connection	Gauge	
ASB						
ASB Standard Accumulator Safety Block core 	M Manually Operated	Split Flange Kits (includes O-ring(s), bolts and washers)	FK3 2" Code 61	FK3 2" Code 61	G1 3000 psi dry	
			FK6 1.5" Code 62	FK6 1.5" Code 62	G2 3000psi liquid fill SS	
		E Solenoid Operated 24v DC Solenoid	Adapter Connector Kits 3000 psi (includes Split Flange Kit)	A31 2" NPT (female)	A31 2" NPT (female)	G3 5000 psi dry
				A36 1 7/8"-12 SAE (male)	A36 1 7/8"-12 SAE (male)	G4 5000 psi liquid fill SS
				A61 1 5/8"-12 SAE (male)	A61 1 5/8"-12 SAE (male)	G5 6000 psi dry
				A62 1 7/8"-12 SAE (male)	A62 1 7/8"-12 SAE (male)	G6 6000 psi liquid fill SS
	E1 110v/115v AC solenoid	Four Bolt Flange Adapter Plate Kits (includes O-ring, bolts and washers)	P31 2" NPT (female)	P31 2" NPT (female)	00 (None)	
			P61 1.5" NPT (female)	P61 1.5" NPT (female)		
			P66 1 7/8"-12 SAE (female)	P66 1 7/8"-12 SAE (female)		
			000 (None)	000 (None)		
			No Connection (Block is drilled for Split and four-bolt flanges)			

Component Parts (When ordered separately from the block)			
Connectors	Size /Type Thread	Kit Part No.	Component Part No.
Split Flange Kits (includes O-ring(s), bolts and washers)	2" Code 61	AI-SB-FK3	
	1.5" Code 62	AI-SB-FK6	
Adapter Connector Kits 3000 psi (includes Split Flange Kit)	2" NPT (female)	AI-SB-AK31	AI-SB-A31
	1 7/8"-12 SAE (male)	AI-SB-AK36	AI-SB-A36
Adapter Connector Kits 6000 psi (includes Split Flange Kit)	1 5/8"-12 SAE (male)	AI-SB-AK61	AI-SB-A61
	1 7/8"-12 SAE (male)	AI-SB-AK62	AI-SB-A62
Four Bolt Flange Adapter Plate Kits (includes O-ring, bolts and washers)	2" NPT (female)	AI-SB-PK31	
	1.5" NPT (female)	AI-SB-PK61	
	1 7/8"-12 SAE (female)	AI-SB-PK66	
Attachments	3000 psi	6000 psi	
Split Flange Bolts (4)	AI-SB-M01	AI-SB-M02	
Adapter Plate Bolts (4)	AI-SB-M03	AI-SB-M04	
Bolts Washers (4)	AI-SB-M05	AI-SB-M06	

O-Ring Designations For the Split Flanges

2" Code 61 AI-SF3-410
 1.5" Code 62 AI-SF6-410

For Adapter Connectors 3000 psi
 (male side)
 1 7/8"-12 SAE AI-A36-410

For Adapter Connectors 6000 psi
 (male side)
 1 7/8"-12 SAE AI-A62-410
 1 5/8" SAE AI-A61-410

For the Four Bolt Flanges
 2" NPT AI-SF3-410
 1.5" NPT AI-SF6-410
 1 7/8"-12 SAE AI-SF6-410

Replacement Solenoid Cartridge Valve
 ASB-E-404

**Note: Custom Parts are available
 for special applications
 at additional cost and extended lead times.**

NEW! Machined Parts for all Industrial Applications NEW!

Accumulators, Inc. maintains a worldwide network of expert machine shops and other metalworking facilities for our various metal parts needs. Because of our extensive relationships and significant economies of scale, we have become specialists in the sourcing of machined parts. We have the capability to quote, inspect, stock and invoice for all your specialty machined parts needs, not just hydraulic parts and components. If you currently source machined parts and are looking for a better price, shorter lead time or just an alternate source, please send a drawing and details to info@accumulators.com and we will do the rest. As always, all drawings will remain confidential and proprietary to your requirements only.



- **CNC Parts**
- **Cast Parts**
- **Milled Parts**
- **Stamped Parts**
- **Screw Machine Parts**
- **Threaded Parts**
- **Forged Parts**

We can meet many type standards and codes. Precision and bulk parts available.

We are experts in designing, sourcing, inspecting and supplying Specials and Custom Design parts

Shell Cleaning Procedures

LEVEL I- ALL UNITS

- A. Sand Blast or high speed rotary brush
- B. Remove any foreign materials such as metal shavings, sand or grit
- C. Clean with high pressure air
- D. Inspect for residual
- E. Repeat if necessary

LEVEL II - CUSTOMER REQUEST (Additional charges will apply)

- A. Bath fully in environmentally safe solution for 5 to 10 minutes
- B. Rinse thoroughly in water
- C. Bathe fully in commercial grade, environmentally safe emulsifiable degreaser (10% solution) for 2 to 5 minutes
- D. Rinse thoroughly with water
- E. High pressure water wash
- F. Inspect for residual
- G. Repeat if necessary

LEVEL III - AccuFlushSM

Certified Accumulator Flushing Services. Cleanliness to NAS 1638, SAE 4059D, ISO 4405, AS 4059, API, Department of Defense or other customer required Standards. Call factory for complete details.

CUSTOMER REQUEST

Customer specified procedures

Corrosion Protection Specifications

Part	Water Service (WS)	Special Service (SS)	Extreme Service (XS)
Protective Cap	303 Stainless Steel	300 Series Stainless	300 Series Stainless
Hex Jam Nut	304 Stainless Steel	300 Series Stainless	300 Series Stainless
Oil Port	Electroless Nickel	316 Stainless Steel	316 Stainless Steel
Poppet	304 Stainless Steel	304 Stainless Steel	304 Stainless Steel
Spring	302 Stainless Steel	302 Stainless Steel	302 Stainless Steel
Piston	303 Stainless Steel	300 Series Stainless	300 Series Stainless
Nut	303 Stainless Steel	300 Series Stainless	300 Series Stainless
Anti-Extrusion Ring	Electroless Nickel	Electroless Nickel	Electroless Nickel
Spacer	Electroless Nickel	316 Stainless Steel	316 Stainless Steel
Locknut	Electroless Nickel	316 Stainless Steel	316 Stainless Steel
Interior Shell	Phenolic Coating	Electroless Nickel	Phenolic Coating
Exterior Shell	White Enamel	Electroless Nickel	3-Coat White Marine Epoxy
Bleed Plug	316 Stainless Steel	316 Stainless Steel	316 Stainless Steel
Gas Valve Stem	12L14	316 Stainless Steel	316 Stainless Steel
Metal Backup Ring	304 Stainless Steel	300 Series Stainless	300 Series Stainless

"WS": Designed with internal protection only. Not recommended for outdoor service.
"SS & XS" Designed with internal and external protection

Also available: CS & PS options:

CS. Combination Service: Same as XS but with no special internal or external coatings.
PS. Prime/Stainless Service: Same as XS but no special external coating.

Other special order materials are also available at additional cost and lead time.

FAQs

About Accumulators, Inc. Products, Designs and Facilities

1. **Are Accumulators, Inc. accumulators interchangeable with other manufacturers' accumulators?**

Yes, Accumulators, Inc. catalog accumulators are interchangeable with accumulators supplied by other manufacturers. Accumulators, Inc. units are part for part interchangeable with major competitors and interchangeable for form, fit and function for most of the rest. Our **SPECIAL ORDER** units are proprietary for each customer, and may not be fully interchangeable

2. **Are Accumulators, Inc. components interchangeable with the components manufactured by other accumulator manufacturers?**

For the most parts, yes. Accumulators, Inc. catalog components are 100% interchangeable with the competition. In some cases, however, Accumulators, Inc. parts are of newer design and not fully interchangeable. Many of those older type designs, however, are available from Accumulators, Inc. ACC.INC. **SPECIAL ORDER** components are only available from Accumulators, Inc. An extensive cross-referencing service is available. Contact the Accumulators, Inc. Sales Department for detailed information.

3. **Do Accumulators, Inc. pressure vessels meet any type of codes?**

Most Accumulators, Inc. units are designed to the strict guidelines of the **ASME** Boiler and Pressure Vessel Code and are so stamped with the "U" symbol and registered with the **National Board of Boiler and Pressure Vessel Inspectors**. Many other design approvals or authority reviews, such as **CE (PED), DNV, ABS, API, CRN, Lloyds**, etc. are available by request at additional cost. Acc Inc can also modify existing units under the **ASME "R"** stamp.

4. **What type of testing do Accumulators, Inc. pressure vessels receive?**

Most Accumulators, Inc. pressure vessels are subject to **ASME** specified high-pressure hydro tests, magnetic particle tests, chemical analysis, physical analysis, hardness tests, charpy test analysis, and dimensional inspections. Other tests are available, some at additional cost.

5. **Does Accumulators, Inc. have a quality control program?**

Yes, Accumulators, Inc. has an extensive quality control program that is periodically reviewed by local, state, national and international agencies. All code designs, code quality control records, quality control manuals and procedures are open to authorized inspectors.

The Accumulators, Inc. main facility in Houston, Texas is **ASME** approved to affix the "U" and "R" stamps and is authorized to register vessels with the **National Board of Boiler and Pressure Vessel Inspectors**. The facility also has approved Manufacturing Assessments by **DNV and ABS**.

6. **Are certifications and traceability available from Accumulators, Inc. and what is the fee?**

ASME U-1A Data Reports are available upon request at no charge. Certifications, or Material Certificates appropriate to the respective code(s) are available at additional cost. Shells are traceable to the day of manufacture and bladders to the month of manufacture. All accumulator vessels are registered with the **National Board of Boiler & Pressure Vessel Inspectors**.

7. **Are Accumulators, Inc. products covered by any warranties?**

Yes, We believe that the Accumulators, Inc. product warranty is the strongest in the industry. Our full warranty is located in the back of this catalog.

8. **What is the proper method of bladder storage?**

To obtain the maximum storage life:

1. Leave bladder in the black UV bags they were shipped in.
2. Store in a closed box, lay flat. Avoid folding. If space permits, bladders can be slightly inflated.
3. Do not expose to light, particularly sunlight or fluorescent lighting.
4. Avoid extreme temperatures. Optimal storage temperature is 65^o- 70^o F.
5. Avoid dirt, dust, grease, chemicals and fumes.

Note: It is recommended that prior to installation, Accumulator Units be stored inside, away from extreme cold or heat

9. **Why use dry nitrogen gas (N₂)?**

Nitrogen is a safe, inert, non-explosive gas that is readily available at reasonable costs.

WARNING! NEVER USE SHOP AIR OR OXYGEN!

Shop air has oxygen and when exposed to petroleum based fluids or grease, can diesel (explode) under pressure. Pure oxygen is even more volatile. Other gases are expensive, corrosive or explosive. Helium is not recommended due to permeability, molecular structure, cost and availability.

Caution! While nitrogen is non-explosive, it is still very dangerous when pressurized

There are several grades of nitrogen gas available. For use in bladder accumulators, we recommend Commercial/Industrial Grade. This is the most common grade available and the most cost effective. It has been used with bladder accumulators for over 50 years. The average purity is 99.5%. Higher grade gas is, of course, acceptable. The MSDS is available from the factory.

10. **What oil port threads are available?**

NPT is standard; SAE and Split Flange are optional at no additional cost. Many metric, special NPT, BSP, Flange seal and others are special order items. Call the factory for availability and pricing.

11. **What are the advantages of bladder accumulators versus piston or the non-separator type?**

1. Rapid response to pressure changes and work cycle.
2. Complete separation of gas and fluid.
3. Highly resistant to fluid contamination.
4. Low maintenance, trouble-free operation.
5. Readily available, low cost replacement parts.
6. Eliminates costly down time on expensive systems due to simple repair.

12. **What is the correct pre-charge for an accumulator?**

Each application has different pre-charge requirements. Consult the Applications Section of this catalog for guidance or contact the Accumulators, Inc. Sales Applications Department.

13. **How often should the pre-charge be checked while the accumulator is in service?**

If the accumulator unit is on a high cycle application it should be checked weekly.

If the unit is used for emergency standby, or pressure holding, it should be checked at least once every month.

14. **What is the correct way to pre-charge an accumulator?**

Consult the instructions listed on the accumulator, shipped with replacement bladder kits and in the Accumulators, Inc. Product Catalog.

Generally: Use an **Acc Inc C&G Assembly** and a regulator to slowly (35 psig) pre-charge the unit. This is the most critical part of the pre-charge. Next you may begin to high charge your unit to the pressure required to operate appropriately.

15. **What is the proper way to mount an accumulator?**

The preferred orientation is vertical; however, a horizontal mounting is acceptable with a small loss of efficiency when lubricated properly. Accumulators, Inc. recommends bolting the accumulator to the skid unit using approved mounting brackets. Acc Inc manufactures several acceptable types.

16. **Can Accumulators, Inc. make a special accumulator for my application?**

Yes. We're experts in **Special Orders** design and manufacture. Among our clientele are Fortune 500 companies, government agencies and the military. Each design is proprietary to the customer.

17. **Does Accumulators, Inc. accept any major credit cards? YES!**



18. **How can I request a quote?**

Use our [RFQ tool](#), available on-line, to receive price and availability on any of our products. Of course you can always call us at 713-465-0202, fax us at 713-468-1618 or email us at info@accumulators.com

19. **Is Accumulators, Inc. environmentally conscious?**

Our final manufacturing processes produce no pollution and use only minimal electricity. In addition, we recycle cardboard, office paper, junk mail, glass, plastic and aluminum. Employees are encouraged to bring their recyclables from home as well. We pride ourselves on being Earth-friendly.

Need more Info? See our website at www.accumulators.com. Or call us as 713-465-0202

Bladder Material Specifications

The following chart is for typical applications at moderate cycles and is based on laboratory results. System fluid and contamination can significantly affect performance. Since real world usage can vary widely, Acc. Inc. cannot warrant the acceptability of any particular system **or the expected life of an elastomer product.**

RUBBER COMPOUND	CODE	PEAK RANGE (F)	OPTIMAL RANGE (F)	PERMEANCE	HARDNESS SHORE (A)	TENSILE (PSI)	ELONGATION (%)
Buna-Nitrile	(None)	-10 to 210	35 to 160	5	60	2000	500
Low Temp Buna-Nitrile	L	-60 to 200	-25 to 145	26	45	1500	500
Butyl	B	-45 to 200	35 to 160	3	60	1500	475
Ethylene- Propylene (EPR)	E	-55 to 300	35 to 250	20	60	1500	500
Fluoro-Elastomer	V	+10 to 480	35 to 350	2	60	1200	400
Extreme Low Temp Nitrile	XL	-80 to 200	-25 to 145	*	60	1600	400
High Temp Nitrile	XH	+10 to 300	35 to 250	*	60	2400	700

Temperature Ranges (F). PEAK: Upper value is based on polymer vendor data. Lower value is based on ASTM D-1053. OPTIMAL: Based on good hydraulic practices. Extended operation beyond these temperatures will shorten the life of the bladder. *Unavailable at press time

The use of compatible clean fluids is highly recommended. Proper filtration is necessary. High Temperature applications should use oil coolers. Low temperature applications require fluid that is in a liquid state.

Permeance to Nitrogen. Parts per million based on ASTM D-1434.

Physical Properties. Values are nominal and are based on Laboratory results.

Bladder Elastomer Compatibility

There are literally thousands of chemical compounds that bladder elastomer compounds have been tested with. An up-to-date listing of the most popular fluids can be found on our website at www.accumulators.com/rubber-compatibility.html

We also maintain an extensive library of elastomer manufacturers' compatibility tables. Please contact our Sales Applications Department, for you application.

Bladder Special Orders

Accumulators, Inc. manufactures a wide range of special accumulators and bladders that can be adapted to most customer applications.

Bladders can be made with many different types of gas valves, with a wide range of materials, and at many pressure ranges. Many elastomers are available.

Accumulators, Inc. can help you design your special parts.

ACCUMULATOR SELECTION, INSTALLATION AND MAINTENANCE

Accumulators manufactured by **Accumulators, Inc.** have proven to be extremely reliable in a multitude of fluid power applications. Proper selection, installation and maintenance practices can lead to a long and trouble-free life, for the accumulator and the system.

ACCUMULATOR SELECTION

TRAINING.

It is highly recommended that a qualified Fluid Power *Design Specialist* review the selection and design of all accumulator systems. The Fluid Power Society's certification program is an excellent training source for industry professionals. Training and technical information is also available from both the Fluid Power Distributor's Association and National Fluid Power Association. The Fluid Power Educational Foundation supports programs in a number of technical schools and universities.

Authorized **Accumulators, Inc.** Distributor/Service Providers have on-staff professionals that can assist you with the design and manufacture of accumulator systems.

Accumulators, Inc's. experienced staff can also help guide you with your selection.

The selection process, while being fairly straight forward, does involve several important factors that must be addressed. System planners often specify familiar components used in previous designs, when they should be taking into consideration changed or additional parameters found in the new system. Each of the following factors should be evaluated on a system-by-system basis to ensure a successful project.

ACCUMULATOR APPLICATION AND SIZING

TYPE of APPLICATION. It is important to determine the Type of application or function. The application type determines sizing and precharge. Additionally the placement of the accumulator, in relation to other components, is dependent on function.

The most common Types are:

1. Energy or Fluid Storage used for auxiliary or emergency power requirements and pressure holding.
2. Shock Cushioning used to reduce pressure waves or "Water Hammer".
3. Suction Stabilization, when pump demands intermittently exceeds the feed line.
4. Pulsation Dampening used to smooth out the flow and pressure of piston pumps.
5. Supplemental Fluid Source for reserve fluid source, leakage and temperature compensation, pressure holding, and energy make-up.
6. Fluid Dispensing used to supply small fluid volumes for lubrication.

More detailed information concerning Application Types is available in *Hydraulics and Pneumatics Magazine's* 2004/2005 Fluid Power Handbook & Directory. Additional information is contained in this catalog.

TYPE of ACCUMULATOR. There are generally six types of accumulators, each with its own inherent advantages and disadvantages.

1. Bladder Accumulators. Excellent for rapid response, complete separation of gas and fluid, contamination tolerant, low maintenance, easy to repair. Precharge must be maintained at all times.
2. AccuMight Diaphragm Accumulators. Excellent for mobile applications, complete separation of gas and fluid, contamination tolerant, low maintenance, easy to repair. Precharge must be maintained at all times
3. Piston Accumulators. Available in many sizes, fair separation of fluids and gas, moderate maintenance, reliable. Requires very clean fluids, difficult to repair.
4. Buoyant Float Accumulators. Accumulators, Inc's. Patented unit. Rapid response, extremely high and low temperature operating ranges contamination tolerant. For low cycling and emergency power applications only.
5. Spring accumulators. Simple design, low maintenance. Limited applications
6. Weight-loaded. Simple design, reliable. Bulky and not commercially available.

SYSTEM REQUIREMENTS. In order to select the correct accumulator unit, the designer must have the following parameters available:

1. Flow rate, and total fluid volume required. This can be determined in a number of ways and requires pump, piping, cylinder and other component specifications.
2. System maximum working pressure. Calculated peak demand, as well as intermittent and momentary

- “spikes”, must be taken into consideration. All components that affect pressure, such as pumps, valves, cylinders, and the often-ignored piping, must be taken into account.
3. System minimum working pressure.
 4. Ambient, Minimum and Maximum Fluid Temperatures. Actual operating temperatures within the accumulator are often well beyond those calculated. In cases such as these the accumulator becomes a heat sink.
 5. Fluid Specifications. Can be obtained from supplier. Often available with the MSDS.
 6. Cycle timing. Whether hours or milliseconds, the “work” and “recover” time is important.

With this information in-hand, the following can be determined:

PRESSURE: The accumulator design Maximum Allowable Working Pressure (MAWP) should meet or exceed the system maximum pressure. System spikes must be identified and accounted for. ACC INC accumulators are available in 3000, 6000 and 10,000 psi models. Never use the accumulator’s Proof or Design Burst Pressure in your assessment. (Installation of an accumulator with a MAWP exceeding the system MAWP is safe and acceptable).

DESIGN CODE: Some applications require the accumulator to meet ASME or other design codes. The location of the system installation or the type of system often will require a specific inspection agency or quality standard. Code requirements should be determined prior to specification. **Accumulators, Inc.** can meet most design codes and agency approvals.

SIZING: The selection of the proper size accumulator is important for efficient operation. If too small, there may be insufficient capacity to do the job. Sizing is dependant on the type of application. Calculations are based on variations of Boyle’s law. Sizing formulae are available on the Accumulators, Inc. website, in this catalog, and in a number of industry wide publications. There are also numerous sizing programs available.

FLUID COMPATIBILITY: As with all hydraulic seals, it is important that the system fluid be compatible with the accumulator’s elastomer compound. Several compounds are available. Compatibility charts are available at www.accumulators.com and many rubber manufacturers’ websites, this catalog, and in a number of industry wide publications. Extensive information is also available from the Rubber Division of the American Chemical Society at <http://www.rubber.org/>. For metal surfaces, additional corrosion protection is required, when high water content fluids are used. Stainless steel, phenolic coating or electroless nickel can be specified.

TEMPERATURE: Each type of elastomer compound has associated Minimum and Maximum temperatures. The designer must ensure that the system does not exceed this range. See “Bladder Material Specifications” above.

PRECHARGE: The proper nitrogen gas precharge is crucial to the operation of any accumulator. It is generally a percentage of the Min or Max working pressure of the system, determined by the Type of application. The calculation is part of all sizing formulae.

CONNECTIONS, PLACEMENT AND ORIENTATION: As with all fluid power components, the connection, placement and orientation of the accumulator can affect the efficiency. Since every system is different, it is up to the user to determine the best arrangement.

Once the designer has all the parameters and determines all the requirements, the selection process is almost complete. The final step is to buy the unit. As straightforward as this may seem, it is often a point of major miscommunication. While the designer may have all the data, it is up to the buyer to give the accumulator supplier the correct specifications. Needless to say, care should be taken, at each step, to make sure the correct information is supplied.

With your new accumulator in hand, all that remains for worry-free operation is correct installation, commissioning, and maintenance!

ACCUMULATOR INSTALLATION

Installation may seem, to many, a very simple process, but it is perhaps the most misunderstood procedure in the life of an accumulator! We have heard this said thousands of times: *“I’ve been installing accumulators for years; I know what I’m doing!”* Fact is, many do not or at least don’t follow ALL of the following recommendations.

TRAINING

Again, it is highly recommended that a qualified Fluid Power **Installer** prepare and place any system’s accumulators.

Authorized **Accumulators, Inc.** Distributor/Service Providers have on-staff professionals that can assist you



2009 Product Catalog

1175 Brittmoore Rd. Houston, TX 77043-5003 USA

voice: 713-465-0202 fax: 713-468-1618

[e-mail: info@accumulators.com](mailto:info@accumulators.com)

with installation.

The following guidelines should be considered in the accumulator's installation:

COMMISSIONING

1. Carefully remove the accumulator from the factory packaging. Read and understand all factory labels, stickers, tags and nameplates attached to the accumulator and the packaging. Read and understand any written factory instructions accompanying the accumulator.
2. If the accumulator is part of a third party OEM system, read and understand all OEM labeling and instructions.
3. Inspect the unit for visible damage, and verify correct part number and thread types.
4. Units are generally shipped from the factory with no precharge. User **MUST** precharge the unit prior to operation. Follow all the steps listed in "**Bladder Care Instructions**", below.

PRECHARGING AND START-UP INSTRUCTIONS

PRECHARGE

See BLADDER CARE INSTRUCTIONS section of this catalog.

INSTALLATION

For most systems, the installation process is a matter of placement, connection and operation.

1. **Placement** of the accumulator in the system is generally specified by the system designer. In these cases the installer should take a "reality check" to make sure the selected location is: **Feasible**. Is there enough space for the unit including mounting hardware and some maneuvering area? **Sensible**. Is the unit close to the "work"? Is it secured properly? Is the connection of similar size to the line? **Accessible**. Will maintenance personnel be able to check the unit for leakage and properly maintain precharge?
2. **Connection**. The designer may select from a number of available threaded or flanged fluid connections. It is up to the installer to have the correct mating parts and any necessary seals not supplied with the accumulator. The connection should be in the same scale as the piping. (A quarter inch connection on a six-inch pipe may not be very efficient). Fittings should be of sufficient pressure rating.
3. **Install** the accumulator on the system. Make sure the connection is tightened appropriately for the selected type of connection
4. Pressurize the system. **CHECK FOR LEAKAGE.**
5. Operate. Following initial operation, check the accumulator precharge and also check for fluid and gas leakage. See BLADDER CARE INSTRUCTIONS below.

With your new accumulator installed, all that remains for worry-free operation is proper maintenance!

ACCUMULATOR OPERATION AND MAINTENANCE

Accumulators, Inc. accumulators generally work so well, that their operation and maintenance is virtually ignored by plant personnel. Only after a good deal of abuse or neglect does anything go wrong. At that point system failure can occur and the accumulator may be damaged.

These costly repairs and downtime can be avoided by proper operation and basic maintenance.

TRAINING

Once again, it is highly recommended that a qualified Fluid Power **Mechanic** perform the maintenance on accumulator systems.

Most **Accumulators, Inc.** Authorized Distributor/Service Providers have on-staff professionals that can assist you with operation and maintenance. In addition, only **Accumulators, Inc.** has a nation-wide **Service and Repair Center** program.

The following guidelines should be considered in the accumulator's operation:

INTENDED OPERATION

Initial design and installation of the accumulator system is based on the **SPECIFICATIONS** provided by the user to the system manufacturer, who in turn provided information to ACC INC. Your system was based on the following **DESIGN PARAMETERS**:

1. Flow rate, and total fluid volume required. This was determined by the pump, piping, cylinder and

- other components' specifications.
2. System maximum working pressure. Calculated peak demand, as well as intermittent and momentary "spikes", was taken into account.
 3. System minimum working pressure.
 4. Ambient, Minimum and Maximum Fluid Temperatures
 5. Fluid Specifications.
 6. Cycle timing.

Most system manufactures provide detailed operating instructions, as well as classroom and on-site training. System operators and mechanics should familiarize themselves with these instructions. **Accumulators, Inc.** provides written instructions with all its units as well as labeling, alerting everyone to possible danger:

Always think **Safety!**

- Wear proper eye protection
- Wear steel toed shoes
- Take proper safety precautions

***NOTE:** Most accumulators are shipped from the factory with minimal pressure. It is the responsibility of the user to determine the proper precharge level and to insure that that pressure is maintained at all times. In general, precharge should equal 30% to 80% of the maximum system pressure.*

REAL-WORLD OPERATION

Once a system is in actual operation, it is time for a *reality check*. Have ANY of the DESIGN PARAMETERS changed from the initial intended operation?

Flow rate, and total fluid volume, working pressures, demand, fluid temperatures or cycle timing. Is the intended fluid being used?

Any change in one or more of these conditions may require a different accumulator for peak efficiency.

ON-GOING OPERATION

Over time operating conditions do change. Periodic review of the operating conditions will insure efficient accumulator operation. Once again ask the question Have ANY of the DESIGN PARAMETERS changed?

Particular attention should be given to the system fluid: As other components wear, fluid may become contaminated, or breakdown, operating temperatures can change and leakage can take place. Any change in any system variable WILL affect the accumulator.

MAINTENANCE

Precharge is the most critical accumulator maintenance issue. An improper precharge level will cause a decline in accumulator efficiency. An extremely low precharge will cause bladder damage. Make sure system operating parameters have not changed since installation.

For cycling applications, check the precharge weekly. For non-cycling applications, check monthly.

You will normally lose some gas, over time, due to *permeance* (the slow leakage of gas through the bladder). A more rapid loss may indicate a gas valve problem. **Complete loss of gas can indicate a broken bladder.**

See BLADDER CARE INSTRUCTIONS below.

Other factors to periodically review that can reduce efficiency or damage the accumulator.

- Is the system fluid contaminated? Have fluid properties broken down?
- Is the fluid level reduced? Are there system leaks?
- Has the operating temperature changed?
- Are system components at optimum condition? Wear and tear on the system can change system parameters affecting the system temperature, cycle time and pressure.
- Have the system requirements changed? A change in the system operations can affect the system temperature, cycle time and pressure.

If a new or different accumulator is indicated, or a modification of an existing unit is required, or if repairs are necessary, contact your local **Accumulators, Inc.** Authorized Distributor/Service Provider.

BLADDER CARE INSTRUCTIONS

BLADDER REPLACEMENT ACCUMULATOR PRECHARGING ACCUMULATOR PRECHARGE MAINTENANCE ACCUMULATOR COMMISSIONING

(For 3000, 4000, 5000, 6000 and 10,000-psi Accumulators)
(Does not apply to Gas Bottles, Transfer Barrier and Float Accumulators and AccuMights)

WARNING: NEVER USE OXYGEN OR SHOP AIR!
This can be extremely dangerous and will void your warranty.

- ✓ Precharge with **DRY NITROGEN (N₂) GAS ONLY!**
- ✓ Never operate accumulator without nitrogen gas precharge.
- ✓ Release all system *hydraulic* pressure before attempting any maintenance or service.
- ✓ Use only genuine ACC INC approved charging and gauging equipment for precharging and pressure check.
- ✓ Follow all instructions below.
- ✓ Wear proper eye protection
- ✓ Wear steel toed shoes
- ✓ Take proper safety precautions

NOTE: All bladders are shipped from the factory with no precharge. Most accumulators are shipped with just minimal pressure. It is the responsibility of the user to determine the proper precharge level and to insure that that pressure is maintained at all times. In general precharge should equal 30% to 80% of the maximum system pressure.

BLADDER REPLACEMENT- REMOVAL

1. Turn off your system (equipment), release all pressure.
2. Remove gas protective cap and valve cap from accumulator.
3. Install genuine ACC INC approved charging and gauging assembly on gas valve stem. Attach the air chuck to the accumulator bladder gas valve by hand tightening its swivel hex connection. For Top-Repairable models use a TR Valve Extension (AI-TR-015)
4. **For 3000 psi accumulators.** Turn the air chuck " T " handle clockwise until it stops. This opens the valve core. **For 4000 psi and higher accumulators.** Open the valve by turning its top (small) hex nut, counter-clockwise.
5. Bleed off all nitrogen gas by opening up the bleed valve completely. (For 4000 psi or higher accumulators, the gas valve must also be opened)
6. Remove the gauging device from gas valve stem.
7. Release any remaining gas pressure from accumulator. (For a 3000-psi accumulator, remove the valve core from gas stem using core tool. For 4000-psi or higher accumulators, open the gas valve fully, then remove gas valve)

WARNING. HIGH PRESSURE GAS IS DANGEROUS!
Wear proper eye protection. Take proper safety precautions

8. Remove accumulator from system.
9. Remove hex jam nut and nameplate.
10. Remove lock nut from bottom of unit using spanner wrench.
11. Remove spacer and rings.
12. Push the plug assembly into the accumulator and through the Anti-Extrusion ring, remove AE ring by folding it and pulling it through the hole.
13. Remove plug assembly.
14. Pull the old bladder out of the bottom of the accumulator.

BLADDER REPLACEMENT- INSTALLATION

1. Remove the valve core on a 3000-psi accumulator or the gas valve on a 4000-psi or higher accumulator from the new bladder. Squeeze all the air out. Replace the valve core or gas valve. Unfold bladder completely.
2. Reinstall the valve core or gas valve
3. Lubricate the bladder and shell with system fluid
4. Attach a bladder pull rod to the bladder by carefully threading over the Schrader connection. Stick the rod through the accumulator (bottom to top). Pull bladder through. Do not allow the bladder to bind or kink.
5. Remove the pull rod
6. Attach the nameplate and hex nut to the exposed gas valve stem. Hand tighten
7. Push the plug assembly, then anti-extrusion ring into the accumulator.

Caution: DO NOT BEND OR FOLD THE BLADDER!

This can cause the bladder to burst

8. Pull the plug assembly through the anti-extrusion ring. Seat ring in the hole, metal side down.
9. Install a NEW metal back up washer, NEW O-ring. (Be careful not to pinch the O-ring), NEW rubber back up ring, spacer, and lock nut (hand tighten).
10. Precharge the accumulator (See Instructions below).
11. Tighten hex jam nut making sure the gas valve stem does not rotate
12. Tighten locknut on fluid end.

PRECHARGING INSTRUCTIONS

➤ **If the accumulator is already installed on a system**

1. Pump a small amount of system fluid (10% of accumulator capacity) into the accumulator, at low pressure. (Do not exceed 35 psi)
2. Turn off all power to the system and release all hydraulic pressure from the accumulator.

➤ **If accumulator is not yet installed:**

1. Place a small amount of fluid (10% of accumulator capacity) into the accumulator. Lubricate as much of the bladder surface area as possible.
2. Remove the protective cap (gas valve guard) and the valve cap (if there is one).
3. Attach the gland & nut portion of the charging assembly (CGA-580 for 3000 psi accumulators, CGA-677 for 4000 psi and higher) to a dry nitrogen gas bottle, tighten securely. If the gland & nut do not fit, you are using the wrong gas or wrong pressure!
4. Attach the air chuck to the accumulator bladder gas valve by hand tightening its swivel hex connection. For Top-Repairable models use a TR Valve Extension (AI-TR-015)
5. **For 3000 psi accumulators.** Turn the air chuck " T " handle clockwise until it stops. This opens the valve core. **For 4000 psi and higher accumulators.** Open the valve by turning its top (small) hex nut, counter-clockwise.
6. Set nitrogen bottle gas regulator (if attached) to 35 psig. (The use of a nitrogen gas regulator is strongly recommended!)
7. Open nitrogen bottle gas valve. (If you are not using a nitrogen gas regulator, care should be taken to slowly "crack" the valve open.) With a regulator, valve can be opened fully.
8. Pre-charge slowly (35 psig) using dry nitrogen gas, until bladder is fully inflated.

Caution: INITIAL PRECHARGING AT A FLOW RATE ABOVE 35 PSIG WILL CAUSE THE BLADDER TO BURST

Make sure to precharge to minimum of 30% of operating pressure

9. Continue pre-charging to desired pressure by increasing gas flow slowly.
10. **For 3000 psi accumulators.** Turn the air chuck " T " handle COUNTER-clockwise until it stops. This CLOSES the valve core. **For 4000 psi and higher accumulators.** CLOSE the valve by turning its top (small) hex nut, clockwise.
11. Remove the charging assembly. Check for gas leakage. (The use of gas leak detection fluid or soapy water is recommended.)
12. Tighten hex jam nut and lock nut fully.
13. Replace the valve cap, protective cap and ACC INC nameplate). Tighten, hand tight.
14. Install accumulator on system. CHECK FOR LEAKAGE.
15. Pressurize system. Operate.

Caution: PRECHARGE MAINTENANCE

For cycling applications check the precharge weekly. For non-cycling applications, monthly.
You will normally lose some gas, over time, due to Permeance.
A more rapid loss may indicate a gas valve problem

1. Release system pressure. Not gas pre-charge.
2. Remove gas protective cap (valve guard) and valve cap.
3. Install gauging device on gas valve stem.
4. For 3000-psi accumulators, screw down air chuck " T " handle, check pressure. For 4000 psi and higher, open gas valve hex fitting (do not loosen from bladder). Check pressure
5. Add additional **dry nitrogen gas** if necessary, using the above procedures.
6. To release excess nitrogen gas (if any) open up bleeder valve, located at bottom of gauging device, until desired pressure is achieved.

NEW ACCUMULATOR COMMISSIONING

Prior to operating a new accumulator on any system a few common sense steps should be taken

1. A qualified Fluid Power specialist should review the accumulator's application for correct sizing, pressure, cycling, connections, placement and efficiency.
2. Carefully remove the accumulator from the factory packaging, read and understand all factory labels, stickers, tags and nameplates attached to the accumulator and the packaging.
3. Read and understand any written factory instructions accompanying the accumulator
4. If the accumulator is part of a third party OEM system, read and understand all of their labeling and instructions
5. All the steps listed in **Accumulator Precharging** (above) should be followed.
6. The proper training of your accumulator maintenance personnel is recommended
7. Consult the factory or your local Accumulators, Inc. Authorized representative, with any questions.

GAS SAFETY CAP

The ACC INC yellow plastic safety cap, located at the top of the protective cap, is designed to "blow-off" if there is a valve stem gas leak. If cap is missing, check pre-charge immediately!

CHARGING & GAUGING RECOMMENDED ACCESSORIES

Item Description	ACC INC Part Number	Pressure
Economy Maintenance Kit	AI-TKITB	3000 psig
Complete Maintenance 3K Kit	AI-TKIT	3000 psig
Complete Maintenance 6K Kit	AI-TKIT-6	6000 psig
Deluxe Maintenance Kit	AI-TKIT1	3000-6500
Charging & Gauging 3kpsi Kit 3000 psig gauge	AI-CG3-KIT-SS	3000 psig
Charging & Gauging 3kpsi Kit 6000 psig gauge	AI-CG3-6KT-SS	3000 psig
Charging & Gauging 6kpsi Kit 6000 psig gauge	AI-CG6-6KT-SS	3000- 6500 psig
Bladder Pull Rod	AI-501 (1 Quart, 1 gallon)	all
	AI-502 (2.5 gal, 5 gal)	all
	AI-503 (10 gal, 11 gal)	all
	AI-504 (15 gal)	all
Valve Core Tool	AI-506	3000 psi
Spanner Wrench	AI-505	all
Lifting Hook Assembly	AI-511	all
Charging valve extension	AI-TR-015	All TR units



Many of these parts are available in our Accumulator Accessory Kits or individually. See pages 31-34

Bladder Storage

1. Bladders are shipped in sealed UV protective black bags. Store bladders in these bags until needed.
2. The cartons in which the bladders were shipped are designed to prolong the storage life of the bladders. Keep the bladders in these boxes until the bladders are needed in service.
3. Keep the tops of the cartons sealed at all times. After removing some of the bladders, reseal the carton.
* By keeping the carton and bag closed, ozone attack from sunlight and artificial lighting will be prevented.
4. Keep the bladder storage area away from sunlight, ultraviolet light, or other ozone producing items, if possible.
5. Optimum storage conditions for bladders are in a dark, cool (72 F) clean room.
6. Rotate your bladder inventory.

Bladder Failure: The Most Common Causes. (non-warranty damage)

1. PROBLEM: STAR BURST (AT BOTTOM OF BLADDER)

Cause 1: Excessively rapid precharging causes bladder to freeze and burst, or extrude through plug orifice before poppet can close.

Solution: Always use an approved nitrogen gas regulator for precharging.

Cause 2: Low Fluid temperature causes bladder to become brittle.

Solution: Use a low temperature bladder.

Cause 3: Lack of lubrication on the bladder causes excessive stretching

Solution 3: Always lubricate bladder prior to use. Use fluids with good lubricity. Use a water service accumulator for water based or low lubricity fluids.

2. PROBLEM: STAR BURST (6" TO 8" FROM BOTTOM OF BLADDER)

Cause 1: Folding of bladder bottom during replacement causes it to be pinned against shell wall. Bladder cannot stretch to close the poppet and it bursts.

Solution 1: Never fold bladder when repairing unit.

3. PROBLEM: POPPET CUT (AT BOTTOM OF BLADDER)

Cause 1: Excessive flow rate causes bladder to extrude down through plug before poppet can close.

Solution: Use a High Flow Accumulator or multiple units of Standard Accumulators

Cause 2: Poppet does not close all the way, which causes the bladder to extrude.

Solution: Inspect plug and poppet assembly for damage, corrosion, or debris. Replace as needed.

Cause 3: Bottom of bladder has hardened due to the reduction of plasticizers from the elastomer, which is caused by excessive heat or chemical degradation.

Solution 3: Use a Viton or other bladder

4. PROBLEM: PICK-OUT (PIN HOLE NEAR TOP OF BLADDER)

Cause: Operation of the Accumulator with little or no precharge allows fluid pressure to force bladder to extrude into gas valve.

Solution: Always operate accumulator with proper nitrogen gas precharge. Check precharge often

5. PROBLEM: BUBBLES, BLISTERS OR RUBBER FLAKING ON BLADDER SURFACE OR BURNT SMELL

Cause: Incompatible fluid, or excessive temperature.

Solution: Refer to rubber compatibility chart and Temperature chart for correct elastomer compounds.

6. PROBLEM: TEARING OF BLADDER AROUND GAS VALVE STEM

Cause: Twisting of gas valve stem during replacement.

Solution: When tightening gas valve hex jam nut, use a second wrench to keep gas valve from twisting. Do not use excessive torque.

7. PROBLEM: GROOVES OR HOLES ON BLADDER SURFACE

Cause: Fluid contamination causes foreign debris entrapment between bladder and shell during cycling.

Solution: Use clean fluid and proper filtration.

8. PROBLEM: RUBBER HAS BECOME BRITTLE CAUSING CRACKS OR FLAKES

Cause: Excessive heat can cause the bladder to re-cure or harden due to the reduction of plasticizers from the elastomer.

Solution: Use a Viton or other bladder and/or install heat exchanger in system. Do not use or store units in hot environment or in direct sunlight.

9. PROBLEM: RUBBER IS BRITTLE IN COLD WEATHER SERVICE

Solution: Use a low temperature bladder.

10. PROBLEM: HAIRLINE CRACKS ON BLADDER SURFACE

Cause: Improper storage. Sunlight, fluorescent light, heat, dust and cold can cause bladder to weather check.

Solution: Store bladder in black bags provided with Accumulators, Inc. bladder kits. Store in 65-75 degree F. dark room.

11. PROBLEM: STRETCHING

Cause: Bottom of bladder has a small poppet mark indicating bladder has stretched due to adherence to wall from insufficient lubrication

Solution: Use a fluid with more lubricity.

Solution: Use a water service accumulator with a coated interior.

12. PROBLEM: SET MARKS ON BLADDER CAUSED ADHERENCE TO SHELL WALL

Cause 1: After precharging, bladder was not cycled for an extended time period

Solution: Do not precharge bladder until just prior to service

Cause 2: Prior to precharging, bladder was not properly lubricated

Solution: Lubricate the bladder and shell prior to precharge

The following causes account for 75% of all bladder warranty claims:

13. PROBLEM: SHARP CUT ON BLADDER SURFACE

Cause: Razor blade or knife used in customer's receiving department.

Solution: Open bladder kits carefully!

14. PROBLEM: BROKEN VALVE CORE

Cause: Excessive torque used to install valve core.

Solution: Order replacement valve core.

15. PROBLEM: BROKEN OR DAMAGED GAS VALVE STEM OR THREADS

Cause: Excessive torque used to install gas charging valve (air chuck).

Solution: Hand tighten gas-charging valve during precharge.

16. PROBLEM: FLUID INSIDE OF BLADDER

Cause: There is a hole somewhere in the bladder.

Solution: Replace bladder.

17. PROBLEM: EXCESSIVE WEAR

Cause: Improper accumulator sizing.

Solution: Contact Accumulators, Inc. technical staff for recommendations.

18. PROBLEM: GAS VALVE STEM CORROSION

Solution: Order special service type bladders.

19. PROBLEM: GAS VALVE IS LEAKING GAS (Valve Stem Repair)

Cause: Dirt may get into the gas valve stem keeping the valve core from sealing.

Solution:

1. Turn off all system pressure, bleed fluid pressure from accumulator.
2. Bleed gas precharge pressure from accumulator
3. Remove valve core and throw it away
4. Using an approved valve core tool, clean the valve stem internal threads. (Do not use the tapered threads).
5. Remove the tool.
6. Using shop air or nitrogen, blow out the cleaned stem.
7. Replace the valve core with a new one.
8. Precharge using Dry nitrogen only. Follow instructions above.
9. Check for leakage using soapy water.
10. If leakage continues replace the gas valve stem.



The above list covers only the most common causes of non-warranty failure. Our in-house QC department, as well as our molders and chemists, have collected a wealth of experience in bladder analysis. There is often additional evidence and factors that can contribute to an evaluation. Most bladder failures are caused by a combination of factors, usually from the list above.

In general, bladder problems can be alleviated by proper sizing, correct compatibility and temperature evaluation, good hydraulic design, proper installation, appropriate precharging, good lubrication, and periodic maintenance. Accumulators Inc. does not warrant systems or fitness for purpose. A qualified fluid power specialist should review any application

IMPORTANT SAFETY WARNING

ALWAYS PRECHARGE ACCUMULATOR WITH DRY NITROGEN GAS (N2) ONLY

ALWAYS USE GENUINE ACCUMULATORS, INC. REPLACEMENT PARTS AND ACCESSORIES. ACCUMULATORS, INC. FULLY WARRANTS ALL ACCUMULATORS, PARTS, AND ACCESSORIES TO BE FREE OF ANY MATERIAL OR ASSEMBLY DEFECTS. SEE PRODUCT WARRANTY FOR ALL DETAILS.

Caution: OPERATION OF ACCUMULATOR WITHOUT SUFFICIENT PRE-CHARGE (MINIMUM OF 30% OF MAXIMUM WORKING PRESSURE) CAN CAUSE BLADDER "PICK-OUT"

Most units are shipped with only 35 psig precharge. You must add additional precharge before operation

Custom Engineered Products

Accumulators, Inc. can design products to fit your precise requirements. We can help you select special fluid or gas ports, special elastomers, and special coatings. These products can be assigned proprietary part numbers for your exclusive use. Perfect for OEM applications

Sizing of Accumulators

Our easy to use sizing program is available under Tech Info, on our website at www.accumulators.com.

Our Sales & Engineering Personnel can also help you with your Application, at info@accumulators.com or call us a 713-465-0202

Accumulator Sizing Formulas

(Sizing of Accumulators is based on the application of the ideal gas laws.)

Nomenclature:

A = Pipe cross - sectional area, ft²

B = Pump cylinder bore area, in.²

g = Gravitational constant, ft/s²

K = Pump constant

L = Pipe length, ft

n = Polytropic constant, typ. nitrogen

P = Normal system pressure, psia

P_i = Initial pre - charge pressure, psia

P_N = Nitrogen bottle pressure, psia

P_{max} = Maximum operating pressure, psia

P_{min} = Minimum operating pressure, psia

P_p = Pre - charge pressure, psia

S = Pump stroke length, in.

V_a = Total volume of accumulator (gas volume), in.³

V_N = Nitrogen bottle volume, in.³

V_x = Volume of fluid collected or discharged by accumulator, in.³

V_1 = Required accumulator volume, in.³

X = Number of accumulators

Y = Number of nitrogen bottles required

v = Fluid velocity, fps

γ = Fluid specific weight, lb/ft³

-sizing for Fluid Storage:

Used for auxiliary power, emergency stand-by power, and pressure holding applications.

$$V_1 = \frac{V_x \left(\frac{P_{min}}{P_p} \right)^{1/n}}{1 - \left(\frac{P_{min}}{P_{max}} \right)^{1/n}}$$

The above equation is based on the adiabatic method. It assumes the accumulator will charge and discharge rapidly, less than one minute cycle time. For applications with longer cycles this equation will give conservative results. The polytropic constant depends on pressure and working pressure. It can be looked up in a good hydraulic or pneumatic handbook.

SIZING FOR LINE SHOCK:

$$V_1 = \frac{12\gamma ALv^2 \left[\left(\frac{P}{P_p} \right)^{\frac{1}{n}} - 1 \right]}{2gP \left[\left(\frac{P_{max}}{P} \right)^{\frac{1}{n}} - 1 \right]} \left(\frac{P}{P_p} \right)^{\frac{1}{n}}$$

Fluid line shock or “water hammer” is caused by the rapid closing of a valve in the line system. An accumulator placed close to the valve will dampen the resulting pressure shock wave.

SIZING FOR SUCTION STABILIZATION:

Rule of thumb: Volume of accumulator = 8 to 10 times the total displacement demand of the pump, per revolution. Note: Fluid connections must allow adequate flow area.

SIZING FOR PULSATION DAMPENERS:

$$V_1 = \frac{BKS \left(\frac{P}{P_p} \right)^{\frac{1}{n}}}{1 - \left(\frac{P}{P_{max}} \right)^{\frac{1}{n}}}$$

The pump constant can be obtained from the pump manufacturer.

QUANTITY OF NITROGEN BOTTLES NEEDED:

$$Y = \frac{P_i V_a X}{V_N (P_N - P_i)}$$

This equation gives the number of nitrogen bottles required to fill a number of accumulators to a specified pre-charge. Round the number of nitrogen bottle up to the next largest whole numbers when figuring the number required. Nitrogen bottle pressure is typically 2400 psig with a volume of 2700 cu. in.

NITROGEN BOTTLES NEEDED WHEN USING A BOOSTER:

$$Y = \frac{P_i V_a X}{P_N V_N}$$

This equation assumes that the accumulators start at one atmosphere of pressure absolute and that the nitrogen bottles will be drained by the booster to one atmosphere of pressure absolute.

Accumulator Polytropic Coefficient:

AVERAGE SYSTEM TEMPERATURE

$\frac{P + P_p}{2}$	Below 100°F	100°F	140°F	170°F	200°F
100 psig	1.4	1.4	1.4	1.4	1.4
200 psig	1.4	1.4	1.4	1.4	1.4
300 psig	1.5	1.5	1.5	1.5	1.5
400 psig	1.5	1.5	1.5	1.5	1.5
500 psig	1.5	1.5	1.5	1.5	1.5
600 psig	1.5	1.5	1.5	1.5	1.5
700 psig	1.5	1.5	1.5	1.5	1.5
800 psig	1.6	1.5	1.5	1.5	1.5
900 psig	1.6	1.6	1.5	1.5	1.5
1000 psig	1.6	1.6	1.6	1.5	1.5
1500 psig	1.7	1.7	1.6	1.6	1.5
2000 psig	1.8	1.7	1.7	1.7	1.6
2500 psig	1.9	1.8	1.7	1.7	1.7
3000 psig	1.9	1.9	1.8	1.8	1.7



2009 Product Catalog

1175 Brittmoore Rd. Houston, TX 77043-5003 USA

voice: 713-465-0202 fax: 713-468-1618

e-mail: info@accumulators.com

Company History

Accumulators, Inc., a Texas corporation, was formed in 1987 by **Jeffry A. Schneider** and **Murry Allewitz**, two leading figures in the bladder accumulator industry. From a humble beginning, Accumulators, Inc. or **ACC INC** has grown into a respected world class manufacturer with a reputation and distribution network second to none.

The bladder accumulator was invented in the 1940's by John Mercier who formed the original Greer/Olear patent group with Edward M Greer. **Jules Kendall**, PE, a long-time staff consultant for ACC INC, joined them and greatly expanded the Engineering Department. Murry Allewitz, an R & D expert from the US Air Force, soon became head of Quality Control.

The Accumulator market grew and prospered. Allewitz moved to the forefront of the industry by introducing new products and applications and by establishing a strong distributor network. As President of Greer he became known as "**Mr. Accumulator**".

In 1980 Allewitz established the Oil Air Industries division of oil field innovator Koomey Inc. Jeffry Schneider, MBA, ASME, a financial executive with an extensive engineering background, joined Oil Air in 1981. Later, under Schneider's leadership as President, Oil Air grew rapidly.

In 1987 both men saw the need for an American owned, independently operated, service-oriented company, specializing in Accumulators. Thus, **Accumulators, Inc.** was born. Servicing both the world-wide petro-chemical market and the fluid power industry, today **ACC INC** is a familiar name.

To further support and promote the distributor group, **Richard T. Kendall** joined the ACC INC team in 1991. His 45 years in Fluid Power industry makes him one of the most experienced people in our business. As Executive Vice President and head of sales, he brings this expertise' to each of our customers and distributors.

Schneider, who became President in 1992, has placed major emphasis on product improvement and innovation with his numerous US and foreign patents. Working closely with outside code and inspection authorities, our **Engineering and Quality** Departments have established a record of performance that is the envy of the industry. Virtually every code agency in the world recognizes ACC INC's superior performance.

In 2006 another key member of the ACC INC team was added. **Scott J. Schneider** joined us and is now VP Operations. Not only did he bring with him years of Industrial Distribution experience gained as Operations Manager at McMaster-Carr Industrial Supply, but also extensive experience in Website design and computer technology. His upgrades to our management systems, as well as our workplace procedures, have allowed us to provide even better service to customers.

The success of ACC INC has been due to a true "**Customer Service**" philosophy. The basic principle is that the Customer is the cornerstone for a successful manufacturer. For over half a century this has proven true in the accumulator industry. Today only Accumulators, Inc. carries on this tradition.

At ACC INC, the customer really is #1. Working with our assigned distributor in each locale, you can depend on our support: with outstanding Service; Product; Reliability; Delivery; and Competitive Pricing. More importantly, you can count on our attitude of encouragement, loyalty, and honest concern.

Accumulators, Inc. most catalog units and parts are fully interchangeable with the products sold by other major suppliers, and meet the strict design requirements of most domestic and international codes. Accumulators, Inc. has also found great success with its "Special Orders" capability.

Our, State-of-the-Art, manufacturing plant is located in Houston, Texas, as are the sales and administrative offices. A rigid **Quality Control** program is in place, which is approved and monitored by **third party, State, National and International** inspection and approval authorities and governments. The facility is authorized by **ASME** to use the "U" and "R" symbols under Section 8 of the code and is authorized by **The National Board of Boiler & Pressure Vessel Inspectors** to register vessels. Accumulators, Inc. also holds the prestigious **CE** mark.

Unlike our competitors, owned by foreign interests or conglomerate corporations in varied industries, you get something special at Accumulators, Inc: **People**. People who know who you are, what you need, and how to solve your problem.

Call us, we'll listen, and more importantly, we'll respond!



HAZMAT SHIPMENTS and DOT EXEMPTION
(FOR ACCUMULATORS WITH NITROGEN PRECHARGE)

Accumulators, Inc. has been issued a special Hazardous Materials Exemption by the
U.S. Department of Transportation



DOT-SP-9998

This exemption, and its extensions, allows Accumulators, Inc. and its subsequent authorized purchasers of Nitrogen Pre-Charged Unmodified Accumulator Assemblies to ship via:

1. **Motor Vehicle, both common carrier and private**
2. **Rail**
3. **Cargo Vessel**
4. **Cargo only aircraft**

Subject to the following restrictions:

1. **Only products manufactured by Accumulators, Inc. are approved**
2. Maximum Nitrogen precharge: 2100 psi @ 70 deg. F.
3. All units must be properly marked, labeled, and documented.
4. Units shipped by subsequent purchasers may not be modified in anyway
5. **Units precharged by subsequent owners must meet all the same shipping requirements as those units shipped from the factory**
6. **All shipments must have a 24 hour Emergency Response Phone number.** ACC. INC. provides this service for shipments direct from the factory. Subsequent purchasers who have registered in advance for this service may use the same number. To avoid the possibility of a large fine, we recommend the use of this low cost service.
7. This exemption does not mandate that carriers accept shipments. Individual carriers may have procedures prohibiting certain type shipments. Contact your freight handler for details.
8. Shipments under "HAZMAT" rules will be at a higher freight tariff and there will be additional costs for DOT mandated documentation.
9. A copy of the exemption must accompany all shipments.

You are advised to read the exemption carefully, and to review the referenced DOT regulations. These regulations apply fully to any subsequent shipper and contain training, record keeping, marking, labeling, documentation and safety rules **that apply to you**. DOT regulations allow inspection of your facility and records if you make use of this exemption.

You are required by Federal Law to have a 24 hour response available for any "H" shipment. We highly recommend that you register your company with an Emergency Response Service, for shipments of Accumulators and other Hazardous Products. You may contact us for further details.

IT IS ILLEGAL FOR ANYONE TO SHIP ANY MANUFACTURERS' PRECHARGED ACCUMULATOR WITHOUT THE PROPER HAZMAT "H" DESIGNATION, DOT EXEMPTION, DOCUMENTATION, MARKING, LABELING, TRAINING AND RECORDS

A copy of the Accumulators, Inc. DOT Exemption is enclosed with each "H" shipment. Additional copies may be downloaded at accumulators.com.



Alternate Design Codes and Inspection Agencies

Most Accumulators sold by Accumulators, Inc. are designed, manufactured, inspected and tested under Section VIII, Div. I for unfired pressure vessels within the ASME Boiler and Pressure Vessel Code.

Most units are stamped with the ASME "U" stamp and have the form U-1A data report available. Additionally, each unit is registered with the National Board of Boiler and Pressure Vessel Inspectors and assigned a unique National Board number.

Accumulators, Inc. is contracted with Bureau Veritas/One CIS Insurance Group. They are authorized by ASME (American Society of Mechanical Engineers) and the State of Texas as our Authorized Inspection Agency (AIA). Additionally, vessels that we have fabricated and tested by our regular outside suppliers may be inspected by other ASME Authorized Inspection Agencies. (Some examples are: Hartford Steam Boiler, Kemper Insurance, Underwriters Laboratory or various city, county or state official agencies.)

There are numerous alternate inspection codes and standards in existence, promulgated by various government, statutory, jurisdictional or industry authorities. Each of these codes has its own qualifying and inspection procedures. Some recognize the ASME code with no further action required. Some require a simple registration. Others require a more detailed registration process and proof of adherence to the ASME code. Others have their own various procedures which are reviewed by an appointed Authorized Inspection Agency (AIA).

Many customers confuse the AIA with the code. Many of these agencies can inspect for more than one code. Consequently, when special orders are received, we must know which agency and which code requirements are requested.

Accumulators, Inc. has formal contracts with several AIAs and working relationships with several others and is familiar with numerous codes. Codes are constantly changing and new codes are often created. The list of which AIAs can inspect for which specific code is also constantly changing. When an inquiry or order is received by Accumulators, Inc., we determine the proper code and current AIA and the costs involved.

The cost for ASME design, manufacture, inspection, testing, stamping and National Board Registration, plus the U-1A data report is included in our list prices. Most alternate codes are at additional cost, which may include:

- | | |
|---|---|
| 1. Application preparation and AIA application fees | 4. Testing, examinations and inspections |
| 2. Documentation preparation | 5. AIA fees for inspections, reports or registrations |
| 3. AIA review fees | 6. Data books |

The following is a list of selected codes and AIAs. It is far from a complete list, and not all are available:

AIAs and Authorities*	Codes*
Bureau Veritas/One CIS	ASME (USA) "U", "R"
Kemper Insurance	D.En. (UK)
Underwriters Lab	NPD (Norway)
Hartford Steam Boiler	USCG (USA)
Det Norske Vertias (DNV)	Service des Mines (Fr)
ABS Americas (Abstech)	TUV (Germany)
Lloyds Register	Stoomwezen (Europe)
Work Health Authority	CSA B51 (Canada) & CRN (Canada)
Delta Lloyds	AS-1210 (Australia)
Lloyds of London	DOT (USA)
TUV	API (USA)
EC (Common Market)	BS 7201 (UK)
"CE" Mark under PED	NR13 (Brazil)
*For a more complete list contact our Engineering Department	



Returned Goods Authorization Procedure

Returned Goods Authorizations (RGA's) are issued by Accumulators, Inc. in order to identify any product returned by the Distributor due to damage, defect, stock adjustment, or shipping error.

Products may only be returned by the original purchaser which is usually an authorized distributor. If you have a product for return and purchased from an authorized reseller, return it to that reseller.

The fastest way to handle a return is to complete the on-line RGA form at www.accumulators.com

1. Distributors must request RGA's from the factory prior to returning any item.
2. To expedite the return, simply enclose a packing slip with the copy of the RGA issued by the factory listing:
Reason for return. Please give details.
Date purchased or original P.O.
Your NEW P.O. for inspection and any non-warranty repairs*

*no fee charged if found to be under warranty

3. Ship the goods to Accumulators, Inc. prepaid, via the least expensive method. **All collect shipments will be refused.** For warranty claims, Accumulators, Inc. may select the carrier.
4. Warranty determination will be made solely by Accumulators, Inc.

A. If we determine that the part is defective, at our discretion we will repair, replace or issue credit for the part and ship it back to you. Warranty evaluation will be made within 45 days from receipt.

B. If we determine that the part is not defective, but damaged due to user error, we will repair the item and charge you for evaluation, testing, repair, any necessary parts and return freight. Please specify on your PO if you do not want the part repaired or returned at your cost.

5. A. RGA's are issued to original purchaser only.
B. Credits, if any, are issued against future purchases.
C. Credit, if any, will be net of discounts or any special pricing originally applied or re-stocking fees for stock adjustment or ordering errors.

NOTE:

ANY GOODS RECEIVED AT OUR FACTORY WITHOUT AN RGA AND A SERVICE REPAIR PURCHASE ORDER, MIGHT NOT BE EVALUATED AND MAY BE DISPOSED OF WITHIN 45 DAYS WITHOUT NOTICE. YOU MAY NOT BE NOTIFIED.

Accumulators Inc. does not warrant systems, or any products "fitness for purpose". Problems caused by improper sizing, incorrect compatibility or temperature evaluation, poor hydraulic design, improper installation, inappropriate precharging, poor lubrication, or inadequate maintenance are not covered. All applications should be reviewed by a certified fluid power specialist.



2009 Product Catalog
1175 Brittmoore Rd. Houston, TX 77043-5003 USA
voice: 713-465-0202 fax: 713-468-1618
[e-mail: info@accumulators.com](mailto:info@accumulators.com)

**TERMS AND CONDITIONS OF SALE (THE "TERMS OF SALE") BY
ACCUMULATORS, INC. ("SELLER") INCLUDING LIMITED WARRANTY AND
DISCLAIMER OF CERTAIN LIABILITIES**

UPON THE PLACEMENT OF ANY ORDER, REGARDLESS OF MANNER IN WHICH RECEIVED, THE FOLLOWING TERMS AND CONDITIONS SHALL APPLY (THE PARTY PLACING SUCH ORDER BEING HEREIN REFERRED TO AS THE "BUYER") UNLESS THE SELLER AND BUYER HAVE PREVIOUSLY AGREED TO OTHER TERMS AND CONDITIONS BY A SIGNED WRITTEN CONTRACT BETWEEN THEM.

1. SPECIFICATIONS.

The accumulator products and other items sold hereunder, or otherwise provided by Seller, shall be referred to as the "Goods." The Goods shall conform to Seller's standard specifications, unless otherwise requested by Buyer, and were produced in compliance with the requirements of the Fair Labor Standards Act of 1938, as amended.

2. DELIVERY, PAYMENT.

Should Buyer wrongfully fail to accept or pay for any shipment or delivery, Seller may, without prejudice to any other lawful remedy, defer further shipments or deliveries until acceptance thereof or until payment is made by Buyer. Seller may from time to time demand different terms of payment from those specified in Section 4 hereafter whenever it reasonably appears that Buyer's financial condition requires such change; and may demand assurance of Buyer's ability to pay whenever it reasonably appears that such ability is in doubt. If Buyer shall fail to make any payments in accordance with the terms and conditions hereof, or shall fail to comply with such demand by Seller, Seller may, at its option treat such failure or refusal as a repudiation hereof. Interest at the maximum rate allowed by law may be charged on past due accounts. Unless otherwise expressly provided and accepted in writing by Seller, delivery terms are F.O.B. Seller's plant. The Goods will be deemed delivered to Buyer at the plant in good condition and properly consigned. It will be Buyer's risk upon such delivery, and prepayment or allowance or freight by Seller shall not affect this provision. Seller shall not be liable for any injury, loss or damage resulting from the handling or the use of the Goods after such delivery.

3. PRICE CHANGES, ACCEPTANCE; ACKNOWLEDGMENTS.

All catalog prices are subject to change at any time without prior notice, and billing will be at the price in effect on the day the written order acknowledgment of the Goods is sent to Buyer, less any discount available on such date. Prices quoted pursuant to a written quotation will not be subject to change for a period of 45 days, unless otherwise noted thereon. Placement of an order by Buyer will constitute an offer in accordance with the terms hereof and such offer, upon Seller's acceptance at Houston, Texas will constitute the agreement between us. Buyer's order after such acceptance by us will not be subject to cancellation, change or reduction in amount, or suspension by Buyer of deliveries, unless prior to such action Buyer has obtained the written consent of Seller. Upon acceptance by Seller, Seller will provide Buyer with a written acknowledgment of such order by facsimile transmission and upon the date Seller obtains a confirmed delivery of such facsimile transmission, Buyer will notify Seller of any discrepancies in such acknowledgment by 5:00 p.m. the following business day.

4. TERMS OF PAYMENT; FREIGHT.

Terms to Buyer are net 30 days upon approved credit unless other terms are quoted or noted on written acknowledgment. Buyer is responsible for all freight charges and Seller shall determine in its sole discretion the method of shipment of the Goods to Buyer. Seller will use reasonable efforts to follow delivery requests made by Buyer, but shall not be liable for any failure to follow such requests.

5. DELIVERY DATES, RUSH ORDERS; DEFERRALS.

It is understood and agreed that deliveries of Goods will be made in accordance with Seller's regular production schedule. Further, any dates or schedules which may be specified for the delivery of the Goods have been stated only approximately and are estimated from the date of receipt of Buyer's order and the acknowledgment, together with completed information as reasonably requested by Seller, including, but not limited to, specifications of the Buyer, in order to proceed with the manufacture and or order of the Goods. The Company shall not incur any liability, either direct or indirect nor shall any order be cancelled because or as a result of any delays in meeting such dates or schedules. Seller will use reasonable efforts to meet Buyer's requests for rush deliveries. Upon any requests for rush deliveries, Seller shall use its best efforts to ship Goods within seventy-two (72) hours from the receipt of the order for Goods, provided, however, that Seller will not be liable for damages or be deemed to be in default by reason of any failure to deliver within such time or other delay in delivery. Buyer must pay for all charges determined by the Seller for such rush delivery requests, including freight charges, provided that in the event delivery is not made within the seventy-two (72) hour time period, Buyer will not be liable for additional rush delivery charges. In the event that Buyer requests a deferral of shipment or manufacture of any Goods ordered, Buyer will be responsible for the payment of a fee determined by Seller in its sole discretion for such deferral.

6. RESULTS OF CANCELLATIONS.

Any cancellations of orders, prior to shipment of Goods to Buyer shall result in a cancellation charge to the Buyer equal to 15% of the total purchase price, in the event that the Goods are listed in the currently published catalog of the Seller. Any cancellations of orders after the time period provided Buyer for advising of acknowledgment discrepancies, as provided in Section 7 below, shall result in a cancellation charge of 50% of the total purchase price for Goods not listed in the currently published catalog of the Seller, including, but not limited to, special orders and Goods manufactured in accordance with Buyer specifications.

7. INSPECTION

Upon delivery of the Goods to Buyer, Buyer shall immediately inspect the Goods at its own cost and, if the Goods do not conform to the description contained in the acknowledgment (referred to in Section 3 herein) herein or to specification or warranty, it shall give written notice to Seller within ten (10) days after that arrival, of any claim to that effect, specifically setting forth the details of the claim. Failure of Buyer to give Seller such notice shall constitute an irrevocable acceptance of the Goods by Buyer, and Buyer shall be bound to pay the full price of the Goods. The Goods shall not be returnable to Seller after acceptance (unless the return is for nonconformity of the Goods following timely notice as described above) without Seller's written consent, and any return to which Seller consents shall be subject to a handling charge of 15% of invoice price; provided, however, that if such Goods are not of current design return of such Goods to which Seller consents shall be subject to a charge of 50% of invoice price. No credit will be issued for any Goods not listed in Seller's current published catalog. No claims will be recognized in regard to Goods disposed of or returned without Seller's written consent.



2009 Product Catalog

1175 Brittmoore Rd. Houston, TX 77043-5003 USA

voice: 713-465-0202 fax: 713-468-1618

[e-mail: info@accumulators.com](mailto:info@accumulators.com)

8. LIMITATION OF WARRANTIES, REMEDIES AND DAMAGES.

(Warranty)

(a) For a period of one year from the date of shipment, Seller warrants purchased Goods will be free from defects in materials and workmanship in normal use and service. In the event of failure of the Goods to conform to this warranty, Seller will at no cost to the Buyer, at Seller's option either repair the Goods or furnish a replacement for the Goods after test and examination by Seller demonstrates that the Goods are in breach of the above warranty.

(Note: Accumulators, Inc. does not warrant the application, compatibility, merchantability, temperature evaluation, sizing, installation or fitness for purpose of its products, a qualified fluid power specialist should review all applications of our products)

All costs incurred for the installation, removal, or reinstallation is the Buyer's responsibility. To make a warranty claim, the Buyer must obtain a return form from Seller and return the Goods freight prepaid to Seller at, 1175 Brittmoore Rd, Houston, Texas 77043-5003 within thirty days after the defect is discovered with a letter specifying the nature of the failure of the Goods to conform to the warranty and a service purchase order to cover any non-warranty repairs. The Buyer will be responsible for all insurance and freight or other transportation charges to our factory. If test and examination by Seller demonstrates that the purchased Goods are in breach of warranty, the repaired Goods or replacement Goods will be returned to the Buyer freight prepaid. Otherwise, the Goods that were returned to Seller will be reshipped to the Buyer freight collect. THIS WARRANTY EXCLUDES AND DOES NOT COVER DEFECTS, MALFUNCTIONS, OR FAILURES OF THE GOODS CAUSED BY REPAIRS BY PERSONS NOT AUTHORIZED BY SELLER; USE OF THE GOODS WITH UNAUTHORIZED PARTS OR ACCESSORIES; MISHANDLING; IMPROPER INSTALLATION; MODIFICATIONS OR ACCIDENTAL DAMAGE WHILE IN THE POSSESSION OF THE BUYER; FAILURE OF THE BUYER TO PROVIDE REASONABLE AND NECESSARY MAINTENANCE; MISUSE OF THE GOODS. NO WARRANTY OF MERCHANTABILITY, FITNESS FOR ANY PARTICULAR PURPOSE OR OTHER WARRANTY (WHETHER EXPRESS, IMPLIED OR STATUTORY) IS MADE BY SELLER, EXCEPT AS STATED IN THIS SECTION 8. These terms and conditions are a complete and exclusive statement with respect to warranties and remedies for breach of warranty between Seller and Buyer. These warranties cannot be varied, supplemented, qualified or interpreted by any prior course of dealing between Seller and Buyer or by any usage of trade. These warranties and remedies can only be varied or amended by a writing executed by Seller and Buyer which shall quote the provisions hereof which are to be amended and the provisions substituted therefore.

(b) Except for the express warranties provided in Paragraph (a) immediately above, all warranties, whether express or implied, all guarantees, and all representations as to the performance or any other aspect of the Goods, including all warranties which, in the absence of this provision, might arise from course of dealing or custom of trade, and INCLUDING ALL WARRANTIES, EXPRESS OR IMPLIED, OF MERCHANTABILITY OR FITNESS FOR A PARTICULAR PURPOSE, with respect to the Goods, ARE EXPRESSLY EXCLUDED AND DISCLAIMED BY SELLER. No agent, employee or representative of Seller has any authority to bind Seller to any affirmation, representation or warranty relating to the Goods other than as specifically provided herein.

(c) Seller shall not be liable for any loss or damage, including special, punitive, indirect or consequential damages (including downtime) caused by its breach of any of the terms or conditions hereof or otherwise relating to or arising out of the Goods (including the use, manufacture, condition, delivery or presence thereof or any other matter, service or activity relating thereto, whether caused by Seller's breach of contract, negligence or other tortious conduct, or otherwise). The liability of Seller for defective or undelivered Goods and/or the consequences thereof shall be limited solely to (at Seller's option) replacement of the Goods or giving Buyer a credit or refund in the amount of the contracted price of the affected Goods. Except for the said replacement or refund, Seller shall not be liable to Buyer or any other person for, and (unless the same are caused solely by the gross negligence or willful misconduct of Seller) Buyer shall indemnify Seller with respect to any loss, injury (including death) or damage to person or property, and all claims and expenses relating thereto, arising out of or relating in any way to the Goods or the non-delivery thereof.

(d) The remedies of Buyer provided for in these Terms and Conditions shall be exclusive and shall be the sole remedies of Buyer.

9. LIMITATIONS ON INTENDED USERS, COMPLIANCE WITH LAWS.

(a) Except as expressly provided by Seller in writing, the Goods are intended for ultimate purchase and use by commercial or industrial users only, and only for operation by persons trained and experienced in the use and maintenance of the Goods. The Goods are **NOT** intended for consumer use, and Seller's warranties do not extend to, and no Buyer is authorized to extend them to, any consumer or other customer.

(b) Buyer shall comply with all laws, ordinances, rules and regulations (including permit requirements) now in force or hereafter adopted which relate to the Goods or to the purchase, storage, sale or use thereof, or any other matter relating thereto.

(c) Operation of any Accumulators, Inc. product or component beyond the prescribed working pressure, or failure to observe all operating instructions stamped, attached or affixed to the product or contained in service instructions, or inappropriate installation, or use in aircraft is prohibited and expressly voids any warranty.

(d) **THE USE OF ANY GASES OTHER THAN DRY NITROGEN GAS FOR OPERATION OF ANY ACCUMULATOR, INC. PRODUCT EXPRESSLY VOIDS ANY WARRANTY, ALL PRODUCTS LIABILITY AND MAY BE DANGEROUS TO LIFE AND PROPERTY.**

10. INDEMNIFICATION.

Buyer shall indemnify, defend and hold Seller, its agents, representatives, officers and employees harmless from and against all claims, suits, judgments, costs, fines, damages, actions of any kind, losses, expenses (including attorney's fees) and liabilities from infringement (actual or claimed) of patents, inventions, designs, copyrights or trademarks arising from the manufacture, either whole or in part, to Buyer's design, plan, specifications or instructions. Seller makes no representation or warranty that any such Goods will not infringe outstanding patents or other rights of others.

11. FORCE MAJEURE.

Seller will not be liable for damages or be deemed to be in default by reason of any failure to deliver or delay in delivery due to any cause beyond Seller's control, including, but not limited to, fire, storm, earthquake, flood, war, acts of public enemies, rebellion, insurrection, sabotage, epidemic, quarantine restrictions, embargo, labor difficulty, railroad car shortages, interruption of transportation, accident, explosion, riots, laws, rules, regulations, instructions and orders of any governmental authority, or any and all acts of God.

12. TAXES.

Seller's prices do not include sales, use, excise or similar taxes. Consequently, in addition to the price specified herein, the amount of any present or future sales, use, excise or similar tax imposed by federal, state, local or any other governmental authority applicable to the manufacture, sale, purchase or use of the Goods shall be paid by Buyer.

13. CHANGE IN DESIGN.

The Seller, and/or its suppliers, shall be entitled to make any and all changes in details of design, fabrication or arrangement of the Goods as the Seller, and/or its suppliers, in its sole discretion determines will constitute an improvement upon the Goods or any specifications of designs previously furnished to the Buyer.

14. PRODUCTS MADE TO BUYER'S SPECIFICATIONS.

The Seller makes NO WARRANTY WHATSOEVER, except as to title, with respect to products manufactured, and or designed to Buyer's own specifications and the Buyer shall at its own expense, indemnify, defend and hold the Company harmless from and against any claim, suit, loss, fine, damages, action of any kind, judgment, liability, expense (including attorney fees) or otherwise which shall be asserted or brought against the Seller by reason of its manufacturer or sale of such products.

15. INTELLECTUAL PROPERTY RIGHTS.

Buyer shall at all times recognize the validity of Seller's trademarks, copyrights, patents, service marks, proprietary designs and all other intellectual property and acknowledges that Buyer has no ownership or property rights therein. Buyer shall at all times exercise all commercially reasonable efforts to protect Seller's property rights in Seller's trademarks, service marks, patents, logos and all other intellectual property rights of Seller.

16. CERTIFICATES AND OTHER DOCUMENTATION.

Buyer will incur additional charges, the amount of which shall be determined in the sole discretion of Seller, for any requested certificates, additional documentation and third party examinations. Such additional charges shall be due at the time the invoice is due.

17. MISCELLANEOUS.

(a) Limitations of Action. No action against Seller for breach of the terms of sale as specified herein or otherwise relating to the Goods, including, but not limited to a breach of the warranties contained herein, shall be commenced more than one year after the accrual of the cause of action therefore.

(b) No Assignment. Buyer shall neither assign any rights nor delegate any duties under these terms of agreement without the prior written consent of Seller.

(c) Applicable Law. The terms of agreement herein shall be governed by and construed in accordance with the laws of the State of Texas; venue shall lie in Harris County, Texas.

(d) Modification and Waiver. These terms and conditions constitute the entire agreement between Buyer and Seller with regard to the subject matter hereof, and there are no understandings, representations, warranties or other provisions of any kind except as herein expressly set forth. No terms or conditions of any purchase order or other document of Buyer shall be part of this Agreement; and Seller expressly declines to accept any such provisions. Buyer's acceptance of the Goods and the sale thereof to Buyer is subject to the express condition that Buyer accept all terms and conditions hereof, and no alterations or modifications of this document shall be binding on Seller unless agreed to by Seller in writing.

(e) Remedies. The remedies herein reserved to Seller shall be cumulative and in addition to any other or further remedies provided by law or at equity.

(f) Successors. These terms and conditions shall be binding on and shall inure to the benefit of the parties' successors and assigns, subject to Paragraph (b) above in this Section 17.

(g) Severability. If any term, provision or condition contained herein is held to be illegal, invalid or unenforceable under present or future laws, then the legality, validity and enforceability of the remaining terms, provisions and conditions contained herein shall remain in full force and effect and not be affected thereby and this Agreement shall be liberally construed so as to carry out the intent of the parties.

18. MEDIATION

Any and all disputes arising between the Seller and the Buyer involving (i) the interpretation or application of the terms or provisions of or (ii) in any manner whatsoever relating to the Terms of Sale, which cannot be resolved between the Seller and the Buyer, shall, prior to the commencement of any legal action, be submitted for dispute resolution utilizing a mutually agreeable mediator and selecting a mutually convenient time and place for the mediation, which, unless circumstances require otherwise, shall occur not later than ninety (90) days after written notice is received by one of the parties hereto from the other party hereto that the dispute can not be resolved by direct negotiations between the parties hereto.



Member



AccuMight[®] Operating, Precharge and Commissioning Instructions



(For 3000, 4000, 5000-psi AccuMights)
(Does not apply to Accumulators, Gas Bottles, Transfer Barrier and Float Accumulators)

WARNING: NEVER USE OXYGEN OR SHOP AIR!
This can be extremely dangerous and will void your warranty!

- ✓ Precharge with **DRY NITROGEN (N₂) GAS ONLY!**
- ✓ Never operate AccuMight without nitrogen gas precharge.
- ✓ Release all system *hydraulic* pressure before attempting any maintenance or service.
- ✓ Use only genuine ACC INC approved charging and gauging equipment for precharging and pressure check.
- ✓ Follow all instructions below.
- ✓ Wear proper eye protection
- ✓ Wear steel toed shoes
- ✓ Take proper safety precautions

NOTE: Most AccuMights are shipped with just minimal pressure (35 psig). It is the responsibility of the user to determine the proper precharge level and to insure that that pressure is maintained at all times. In general, precharge should equal 30% to 80% of the maximum system pressure.

WARNING. HIGH PRESSURE GAS IS DANGEROUS!
Wear proper eye protection! Take proper safety precautions!

AccuMight Bladder Removal

1. Turn off your system (equipment), release all hydraulic or fluid pressure.
2. Remove gas protective cap (2) and valve cap (3) from AccuMight.
3. Install genuine ACC INC approved charging and gauging assembly on gas valve stem. Attach the air chuck to the AccuMight bladder gas valve by hand tightening its swivel hex connection.
4. **For 3000 psi AccuMights.** Turn the air chuck " T " handle clockwise until it stops. This opens the valve core. **For 4000 psi and higher AccuMights.** Open the valve by turning its top (small) hex nut, counter-clockwise.
5. Bleed off all nitrogen gas by opening up the bleed valve completely. (For 4000 psi or higher AccuMights, the gas valve must also be opened)
6. Remove the gauging device from gas valve stem.
7. Release any remaining gas pressure from AccuMight. (For a 3000-psi AccuMight, remove the valve core (4) from gas stem (5) using core tool (AI-506). For 4000-psi or higher AccuMight, open the gas valve fully, then remove gas valve
8. Remove AccuMight from system.
9. Unscrew the upper portion of the AccuMight using a band wrench and a vise. (AM60 has a removable screw cap(7))
10. Remove bladder (9or10) carefully making sure o-rings (if any) and back-up rings (if any) are removed. Please note the configuration of the components. (Different models have different configurations)
11. Thoroughly clean the interior of the shell sections paying particular attention to the seat area.

AccuMight Bladder Installation

1. We recommend that a new gas valve(5), new o-ring(6) and/or a new valve core(4) be installed.
2. Lubricate the AccuMight bladder and shell with system fluid.
3. Apply a small amount of compatible grease on the new o-ring, new bladder "lip" and shell seat area.
4. Carefully insert new bladder making sure the "seat" is properly aligned
5. Attach the two shell sections
6. Hand-tighten the sections, making sure the bladder and o-ring are correctly seated and are not "pinched".
7. Tighten fully using a band wrench and vise.
8. Precharge the AccuMight (See Instructions below).
9. Reinstall the unit on the system

AccuMight Precharging Instructions

If the AccuMight is already installed on a system

1. Pump a small amount of system fluid (10% of AccuMight capacity) into the AccuMight, at low pressure. (Do not exceed 35 psi)
2. Turn off all power to the system and release all hydraulic pressure from the AccuMight.

If AccuMight is not yet installed:

3. Turn unit upside down (Fluid-end up). Place a small amount of fluid (10% of AccuMight capacity) into the AccuMight. Lubricate as much of the AccuMight bladder surface area as possible.
4. Remove the protective cap(2) and the valve cap(3) (if there is one).
5. Attach the gland & nut portion (CGA-580 for 3000 psi accumulators, CGA-677 for 4000 psi and higher) of the charging assembly to a dry nitrogen gas bottle, tighten securely. If the gland & nut do not fit, you are using the wrong gas or wrong pressure!
6. Attach the air chuck to the AccuMight bladder gas valve by hand tightening its swivel hex connection.
7. For 3000 psi AccuMight, Turn the air chuck " T " handle clockwise until it stops. This opens the valve core. For 4000 psi and higher AccuMight open the valve by turning its top (small) hex nut, counter-clockwise.
8. Set nitrogen bottle gas regulator (if attached) to 35 psig. (The use of a nitrogen gas regulator is strongly recommended!)
9. Open nitrogen bottle gas valve. (If you are not using a nitrogen gas regulator, care should be taken to slowly "crack" the valve open.) With a regulator, valve can be opened fully.
10. Pre-charge slowly (35 psig) using dry nitrogen gas, until the AccuMight bladder is fully inflated.

**Caution: INITIAL PRECHARGING AT A FLOW RATE ABOVE 35 PSIG
WILL CAUSE THE BLADDER TO BURST**

Make sure to precharge to minimum of 10% of operating pressure

11. Continue pre-charging to desired pressure by increasing gas flow slowly.
12. For 3000 psi AccuMights, Turn the air chuck " T " handle COUNTER-clockwise until it stops. This CLOSSES the valve core. For 4000 psi and higher AccuMights CLOSE the valve by turning its top (small) hex nut, clockwise.
13. Remove the charging assembly. Check for gas leakage. (The use of gas leak detection fluid or soapy water is recommended.)
14. Replace the valve cap, protective cap). Tighten, hand tight.
15. Install AccuMight on system. CHECK FOR LEAKAGE.
16. Pressurize system. Operate.

**FAILURE TO FOLLOW PROPER SERVICE AND INSTALLATION INSTRUCTIONS
MAY VOID ACC INC PRODUCT WARRANTY**

AccuMight Commissioning

Prior to operating a new AccuMight on any system a few common sense steps should be taken

- A qualified Fluid Power specialist should review the AccuMight's application for correct sizing, pressure, cycling, connections, placement and efficiency.
- Carefully remove the AccuMight from the factory packaging, read and understand all factory labels, stickers, tags and nameplates attached to the AccuMight and the packaging.
- Read and understand any written factory instructions accompanying the AccuMight
- If the AccuMight is part of a third party OEM system, read and understand all of their labeling and instructions
- All the steps listed in **AccuMight Precharging** (above) should be followed.
- The proper training of your AccuMight maintenance personnel is recommended

Consult the factory or your local Accumulators, Inc. Authorized representative, with any questions

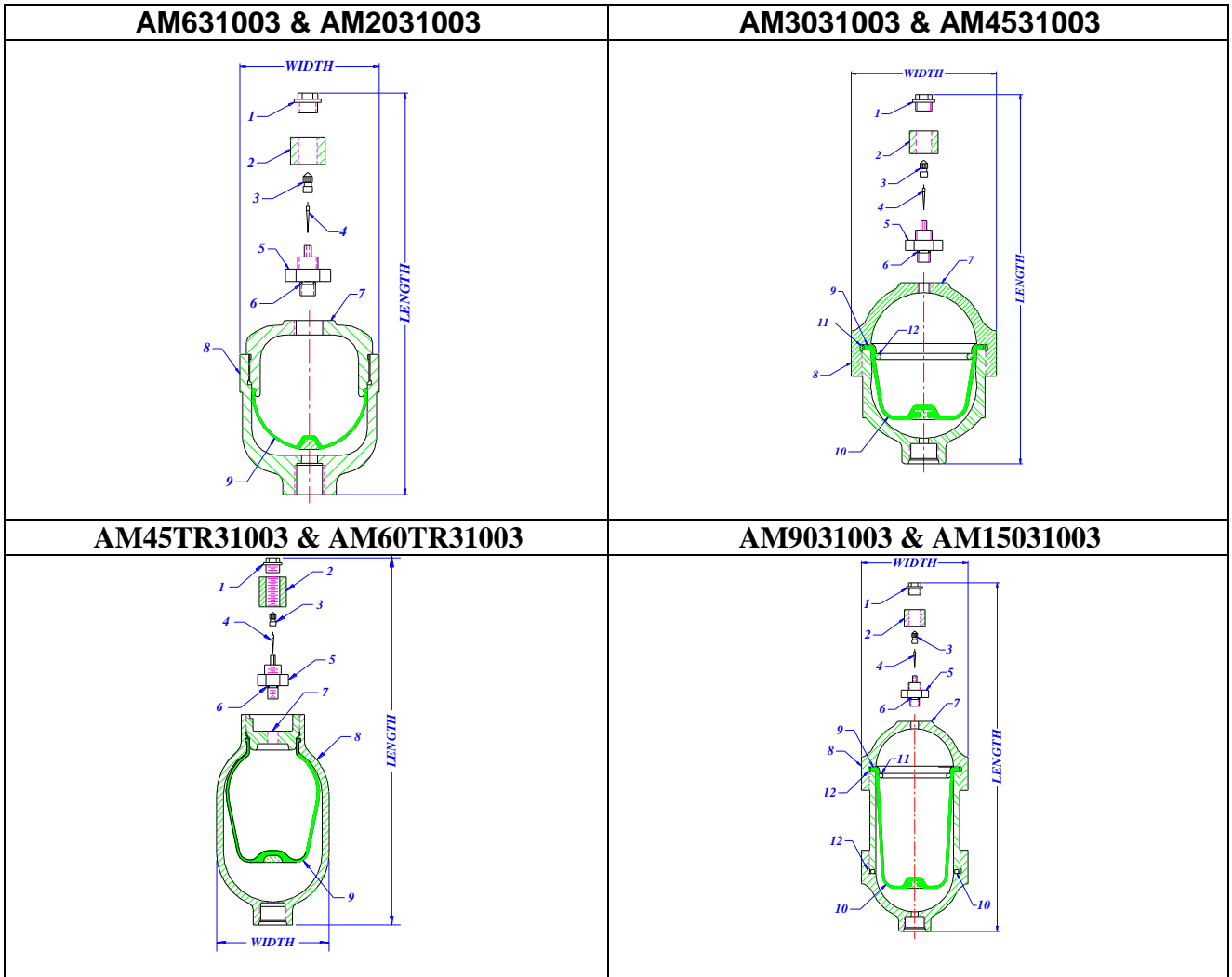

AccuMight Dimensions

Size	3000 psi	Length	Width	Fluid Port	Gas Port
6 ci	AM631003	5.8	3.0	3/4"-16 UNF	.305-32 UNEF
20 ci	AM2031003	6.8	3.9	3/4"-16 UNF	"
30 ci	AM3031003	7.5	4.5	3/4"-16 UNF	"
45 ci	AM4531003	8.2	5.4	1 1/16"-12 UNF	"
45 ci	AM45TR31003	8.3	4.6	1 1/16"-12 UNF	"
60 ci	AM60TR31003	9.0	4.6	1 1/16"-12 UNF	"
90 ci	AM9031003	12.1	5.4	1 1/16"-12 UNF	"
150 ci	AM15031003	18.1	5.4	1 1/16"-12 UNF	"

This is just a small representation of the many variations of AccuMights.

Also Available:

- Low Pressure and High Pressure units
- Various elastomers such as Butyl, EPDM, Silicon and Floral-elastomers.
- Several exotic and corrosion resistant materials such as Stainless Steel and Plastics
- Low cost non-repairable designs

Call the factory for more information

AccuMight Precharge Maintenance

For cycling applications check the precharge weekly. For non-cycling applications, monthly

You will normally lose some gas over time due to Permeance.

A more rapid loss may indicate a gas valve problem

1. Release system pressure. Not gas pre-charge.
2. Remove gas protective cap (valve guard) and valve cap.
3. Install gauging device on gas valve stem.
4. For 3000-psi accumulators, screw down air chuck " T " handle, check pressure. For 4000 psi and higher, open gas valve hex fitting (do not loosen from bladder). Check pressure
5. Add additional dry nitrogen gas if necessary, using the above procedures.
6. To release excess nitrogen gas (if any) open up bleeder valve, located at bottom of gauging device, until desired pressure is achieved.

AccuMight Charging and Gauging Accessories

Item Description	ACC INC Part Number	Pressure
Basic Maintenance Kit	AI-TKITB	3000 psig
Standard Maintenance Kit	AI-TKIT	3000 psig
Deluxe Maintenance Kit	AI-TKIT1	3000-6500
Charging & Gauging 3kpsi Kit 3000 psig gauge	AI-CG3-3KT-SS	3000 psig
Charging & Gauging 3kpsi Kit 6000 psig gauge	AI-CG6-3KT-SS	3000 psig
Charging & Gauging 6kpsi Kit 6000 psig gauge	AI-CG6-6KT-SS	3000- 6500 psig
Valve Core Tool	AI-506	3000 psi

AccuMight Replacement Parts

Part Description	Part Number	Part Description	Part Number
Component List			
Safety Cap	AI-1QT-308	Gas Valve O-Ring	AM-310
Protective cap	AI-1QT-306	Large O-Ring (45,90,15)	AM-410-B
Valve cap	AI-1QT-303	Small O-Ring (90,15)	AM-410-C
Valve Core	AI-S-304	Teflon Ring (45,90,15)	AM-411
Gas Valve	AM-309	Metal Ring (45,90,15)	AM-412
Mounting Hardware			
90-150 U-Bolt	AM-507-KIT	30-150 Base	AM-512
30-150 Collar	AM-507-KIT	Rubber Insert	AM-513

See Page 39 for AccuMight Mounting Hardware

AccuMight Series Repairable Diaphragm Accumulators

The OEM Solution



Repair and Service Center Procedures

(For Warranty Service, please see page 51 of the Catalog)

Accumulators, Inc. offers a complete **Repair and Service Center** for its User/Customers. We can inspect, test, repair and recondition any Accumulators, Inc. product, as well as the products of many other bladder accumulator manufacturers.

In order to control your costs and to expedite your repairs, we offer three levels of Service:

Express Repair (fastest and most economical):

- Completely Disassemble Unit
- Clean Shell housing and Oil Port Assembly
- Replace Bladder and Gas valve, O-ring, Back-up ring, and Metal back-up ring
- Inspect all other parts
- Pre-charge to 35 psig. Attach Warning tag
- Pack and Ship

Not included: Inspection or Testing Reports, non-standard components, new Oil Port Assembly Components, New Labels, Precharge above 35 psig, non-standard packaging, freight, hazardous waste disposal

Standard Repair (fast and moderately priced):

- Everything included in the Express Repair **plus...**
- Disassembly of the Oil Port Assembly, cleansing of parts
- Replacement of Spring, Piston, Nut and Anti-Extrusion Ring
- Inspection Report
- New labels and Warning Tags

Not included: Non-standard components, Testing Reports, non-standard packaging, Precharge above 35 psig, freight, hazardous waste disposal

Full-Service Repair (Unit will be reconditioned as close to "Like-new" as possible):

- Everything included in the Express and Standard repair **plus...**
- Gas Pressure test to 1000 psig. Includes test certificate
- Sandblast the shell interior and exterior, if needed. (Does not apply to WS, XS or SS models)
- Repaint shell exterior with 2 coat enamel

Not included: Non-standard components, non-standard packaging, Precharge above 35 psig, freight, and hazardous waste disposal

Shipping Procedure

1. Drain all fluids and gas from accumulator. **Do not ship a unit with any pressure or fluid.** (A Hazmat or Waste Disposal fee will be charged)
2. Remove all fittings not originally supplied by the accumulator manufacturer
3. **Properly package the unit.** Protect end fittings
4. Enclose a **Repair and Service** Authorization form (available on-line or by fax) or your Service Purchase Order. Indicate what level of service is requested and your ship-to address.
5. Send unit to: **Accumulators, Inc.** Attn: **Repair and Service** Center
1175 Brittmoore Rd. Houston, TX 77043-5003
6. Ship unit **Freight Prepaid.** (Sorry, no freight collect will be accepted)
7. We will repair the unit as requested
8. We will ship the unit back, freight collect. FOB our plant. And bill you.

Accumulators, Inc. will not service any unit that has been altered, or that, in our judgment, could be dangerous to work on, or would not be safe to operate if repaired.

Extra Cost items: Hydrotest, Pressure test, non-standard components, Poppet, Oil Port plug, frozen parts, waste disposal, freight, Hazmat shipping, and special requirements. Standard components are 3000 psi, oil-service, Buna-n parts.

The Accumulators, Inc. limited product warranty (see page 51 of the catalog) applies to any new parts included in a repair. Accumulators, Inc. does not warranty repaired units, or their fitness for purpose.



2009 Product Catalog
1175 Brittmoore Rd. Houston, TX 77043-5003 USA
voice: 713-465-0202 fax: 713-468-1618
[e-mail: info@accumulators.com](mailto:info@accumulators.com)

Index

Subject	Page
Accessories	33
AccuMight Diaphragm Accumulators	6
Accumulators 10000 PSI	18
Accumulators 3000 PSI	10
Accumulators 5000 & 6000 PSI	14
Accumulator Accessory Kits	33
Accumulator Ordering Table	4
Accumulator Safety Blocks	41
Accumulator Selection, Commissioning, Installation & Maintenance	47
Alternate Design Codes and Inspection Agencies	61
Bladder Care Instructions	51
Bladder Elastomer Compatibility	46
Bladder failure: Most common causes & Bladder FAQs	54
Bladder Material Specifications	46
Bladder Replacement - Installation & Precharging	52
Bladder Replacement - Removal	51
Bladder Special Orders	46
Bladder Storage	54
Charging & Gauging Recommended Accessories	53
Charging and Gauging Assemblies & Components	31
Company History	59
Contacting Accumulators, Inc.	2
Corrosion Protection Specifications	43
Custom Machined Parts for all industries	42
FAQ's	44
Float Accumulators	24
Fluid Port Specifications	29
Gas Bottles	21
Gas Valve Specifications	30
HAZMAT Shipments & DOT Exemption	60
Hi-Flow Accumulators	19
Mounting Hardware	36
Permanent Mount Pressure Monitor	35
Piston Accumulators	28
Precharge Maintenance	53
Returned Goods Authorization (RGA) Procedure	62
Shell Interior Cleaning Procedures	43
Sizing for Fluid Storage, Line Shock	57
Sizing for Suction Stabilization & Pulsation Dampeners	58
Sizing Polytropic Coefficient Table	58
Special Order Products	5
Standard Part Number List	3
Tools	40
Transfer Barrier Accumulators	25